



TECHNICAL BULLETIN M/L- 609

VIBRO/DYNAMICS' ISOLATORS ENHANCE PERFORMANCE OF PLASTIC INJECTION MOLDING MACHINES

Vibro/Dynamics Corporation has been a major leader in the design and manufacture of freestanding isolation mounting systems for industrial machinery for over thirty-five years. Already experienced in isolating a wide variety of metal forming and metal cutting machines, Vibro/Dynamics quickly applied this knowledge and experience to the plastics industry.

The use of isolation mounts on plastic injection molders is widely accepted and acknowledged. Today, although there are a variety of mounts available, Vibro/Dynamics' Isolators remain the best choice when installing plastic injection molding machines.

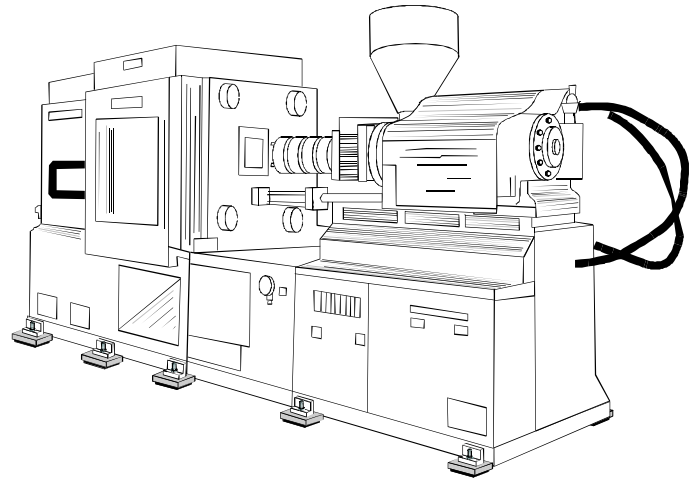

Dynamic Parallelism

Head-to-head testing has proven Vibro/Dynamics' Isolators superior to competitive mounting systems. Several tests, conducted at a major builder of Plastic Injection Molding machines, showed that a plastic molding machine was subjected to less frame distortion when installed on Vibro/Dynamics' Isolators vs. competitive mounts. Results showed that the stationary platen tilted 55% less at the front and 20% less at the rear when mounted on Vibro/Dynamics Isolators than when installed on competitive mounts.

Vibro/Dynamics' Isolators have a unique feature called "Glide/Damping" built in. It provides a small degree of lateral freedom, allowing a machine to move slightly horizontally when sudden inertia forces occur, and then return to its *home* position *without* walking. This feature allows the frame to move as a rigid body due to the inertia forces caused by the opening and closing of the mold or from an emergency stop.

Reduced twisting in the machine's structure results in less wear and tear on molds and tie bars. Vibro/Dynamics' Isolators actually pay for themselves with increased mold life and reduced downtime.

Precision Leveling and Alignment

An injection molder's base may have twenty-four or more mounting points. The base provides support for the guide bars aligning the platens and also houses the controls, pumps, and oil and coolant reservoirs.

During operation, the platens are pressed together with tremendous amounts of force. To produce high quality parts, the platens and molds must fit together exactly. It is critical that guide bars be level and aligned to minimize wear on the molds and the machine.

Plastic molders are intended to be installed and operated in a precisely level and aligned condition. Precise level and alignment is nearly impossible if the machine is bolted down or merely set down on a floor because a floor cannot be poured precisely so that it is level and in one flat plane over its entire area. In most cases, sections of the molder's base will not be properly supported or not support anything at all, causing the machine to bend and twist due to irregularities in the floor.

M

Forces at Work in Plastic Molders

Inherent flexibility of the machine base illustrates Newton's Law of Equal and Opposite Reactions. When the platens are forced together, the ends of the machine are pushed apart with equal force. That is, when the platens are clamped together in a 600-ton Plastic Injection Molder, the ends of the machine are being pushed apart with a force of 600 tons. Since the base of the machine is what holds it together, the base tends to flex or bend upwards under the platens. If the machine were merely sitting on the floor, its ends would tend to dig into the foundation. If it were bolted to the floor, there would be a powerful upward force on the anchoring bolts in the center of the machine as well.

When pressure on the platens is relieved, Newton's Law is at work again. Now the ends of the machine want to come together, causing the machine to bow downward in the middle and upward at the ends.

Combined, these forces can cause a Plastic Injection Molder to walk across the floor, walk off lesser isolation pads or break anchor bolts. Vibro/Dynamics' Isolators eliminate these problems. They are custom engineered for maximum performance under your particular machine. Available in over 25 different sizes, hundreds of load ranges, and thousands of models, they are selected by our engineers for optimum vibration isolation. The correct combination of stiffness, thickness, and size is specified to allow a Plastic Injection Molder to operate correctly, flex just right and return to precise and proper alignment each time the platens move.

The Lod/Sen Option

Lod/Sen is a patented, Electronic Fine-Tuning System (EFT) available as an option *only* with Vibro/Dynamics' Isolators. These "smart" isolators measure the load supported by each isolator, then relay that data to the Lod/Sen Analyzer. This instrument indicates which isolators to adjust, and how much to adjust them, for proper machine support. Used in conjunction with a machinists level, the Lod/Sen System makes it possible to precisely level the molder while insuring that each isolator carries its proper share of the molder's weight. The combination of precise leveling and proper support allows the

molders to be precisely aligned and parallel as intended by the manufacturer.

The Payoff

Vibro/Dynamics' Isolators provide a unique combination of precise leveling, proper alignment, proper support, and reduction of impact forces, vibration and noise. The benefits of this modern method of installing plastic molding machinery can be measured in improved machine performance, longer tool and machine life, higher quality parts, reduced downtime, and increased productivity.

Further Savings

Installing a Plastic Injection Molder on Vibro/Dynamics' Isolators is less expensive than anchoring it to the floor or using competitive mounts. Savings in time and labor alone pay for the isolators before the first part is produced. If the foundation settles, the machine is relocated, or operation is somehow disrupted, releveling it is not a problem.



For additional information on how Vibro/Dynamics' Isolators can improve your current machinery installations, contact us at:

Vibro/Dynamics Corporation
2443 Braga Drive
Broadview, Illinois 60155-3941.
Phone 708/345-2050 or 1-800-842-7668
Fax 708/345-2225
E-mail: vibro@vibroynamics.com
www.vibroynamics.com

Vibro/Dynamics® , Lod/Sen™ , Hydra/Level® and Vibro/Dynamics® are Trademarks of the Vibro/Dynamics Corporation.

©Copyright 1990 by Vibro/Dynamics Corporation.
All Rights Reserved

Patented in the U.S.A. and foreign countries.
MY/MR Revised 8/1/1989
HR/Sales Revised 08/2001