

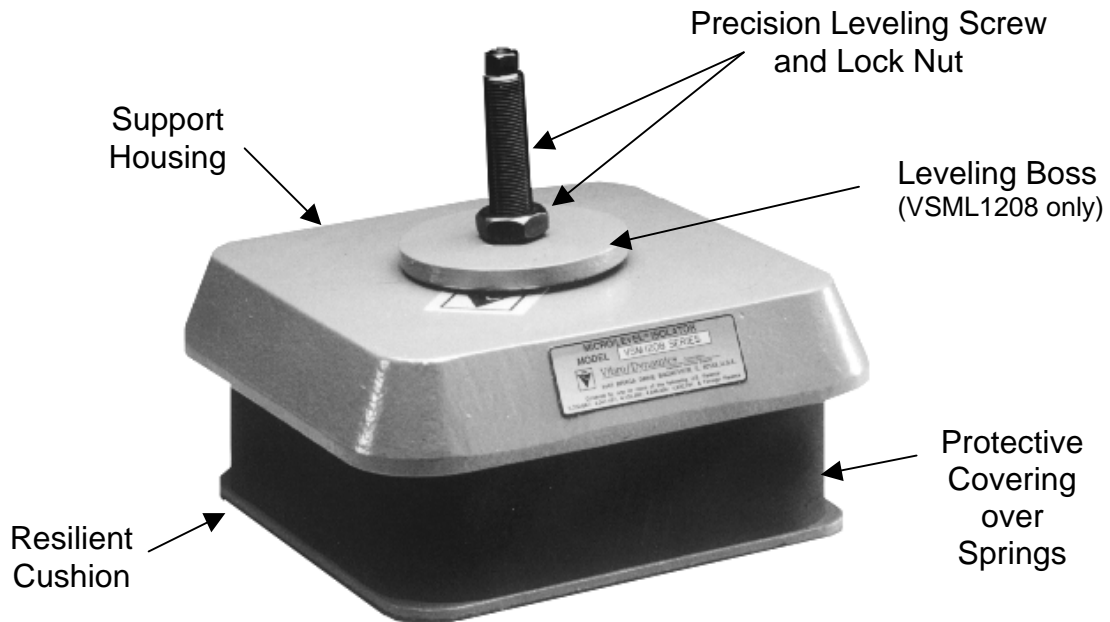

**Technical Bulletin M/L 678**

**Installation and Leveling Instructions for  
Vibro/Dynamics® VSML Hy/Speed® Spring Isolators  
with Integral Leveling**



**VSML1208 Hy/Speed® Isolator**

Vibro/Dynamics' Technologically Advanced Machinery Mounting Systems are an investment in productivity and efficiency. To realize the full potential of your investment, familiarize yourself with these instructions and use them as a reference during the installation.

## VIBRO/DYNAMICS

# INSTALLATION AND LEVELING INSTRUCTIONS

### EQUIPMENT NEEDED

- Hydraulic jacks, crane, forklift, etc. to lift and support machine during isolator installation, and to reduce the load on isolator to make leveling adjustments.
- Precision machinists' or electronic level, or laser leveling device.
- Wrenches for isolator leveling screws and locknuts. (See Table on back page for sizes)

### PREPARATION

1. The concrete surface under the isolator must be clean, flat, and trowel finished. There should not be any holes, cracks, or lumps directly under the isolator.
2. Clean and inspect the machine feet and legs. Repair any cracks or damage. The bottom of the machine feet must be clean and flat where it contacts the top of the isolator.
3. Clean debris from the machine's mounting holes.

### ISOLATOR LOCATION – CRITICAL!

4. If the isolators do not all have the same model number; each isolator will be stamped to indicate its proper location (i.e., flywheel side, opposite of the flywheel side, etc.).
5. Refer to paperwork included with the shipment, installation letter sent prior to shipment or installation drawings if isolator location is unclear. Call Vibro/Dynamics 1-800-842-7668 if assistance is required.

### INSTALLATION

6. Position each isolator under the machine foot so that the threaded hole in the isolator and the machine's mounting hole are concentric as per Figure 1.

**Note:** Machine sets on the top of the Leveling Boss of the VSML1208 isolator model. See drawing on the following page.

7. Insert the leveling screw and thread it into the isolator until it bottoms. Turn the leveling screw an additional turn.
8. Carefully lower the machine onto the isolators.

**Note:** Isolators will deflect up to 1.5" (38 mm).

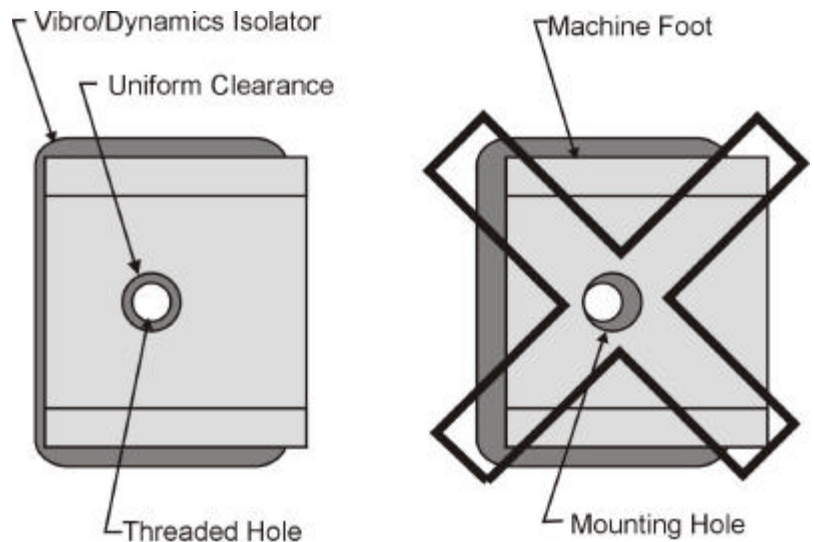

**Figure 1**

## LEVELING

9. Refer to the machine manual for the machine's leveling locations and tolerances.
10. Using a precision machinist's level, or laser, determine the machine's low side in the front-to-back direction. Raise all of the isolators on the low side by turning the precision leveling screws clockwise equal amounts until the machine is level in that direction.
11. Repeat procedure in the left-to-right direction.
12. Repeat Steps 10 and 11 until the machine is level.
13. Recheck the machine's level condition if weight is added to or removed from the machine.

## VERIFY INSTALLED HEIGHT

14. Measure the loaded height of the isolators using the positions shown in the figures on the right. If the isolators fall within their proper range, proceed to Step 18.
15. If one or more isolators are compressed too much, make sure that they are all in the correct locations as per Steps 4 and 5. Do not operate the machine if any isolator is compressed more than its minimum operating height.
16. If one diagonal set of isolators is compressed too much, then raise the opposite set of isolators. This increases the load on that pair and decreases the load on the over-compressed set of isolators. If this is successful, recheck level as per Step 10.
17. If any of the isolators measure outside of the Operating Height Range, and leveling does not improve the condition, contact Vibro/Dynamics Corporation 1-800-842-7668.

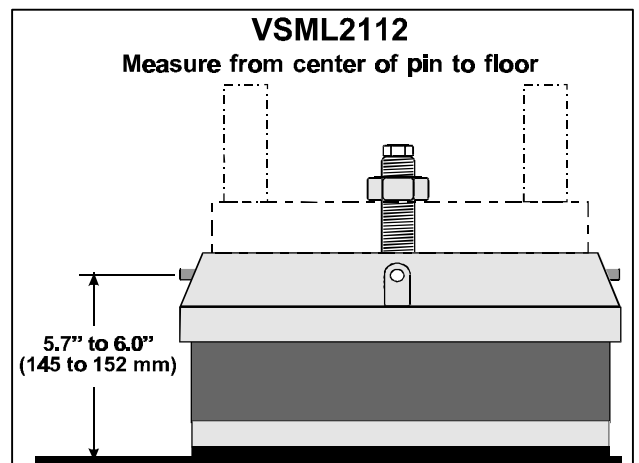
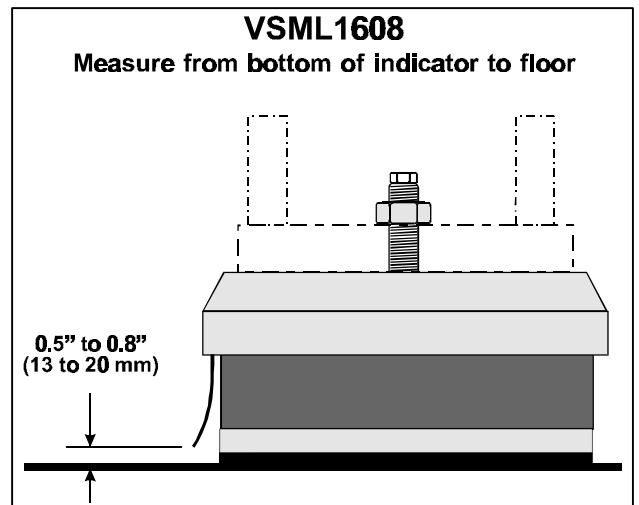
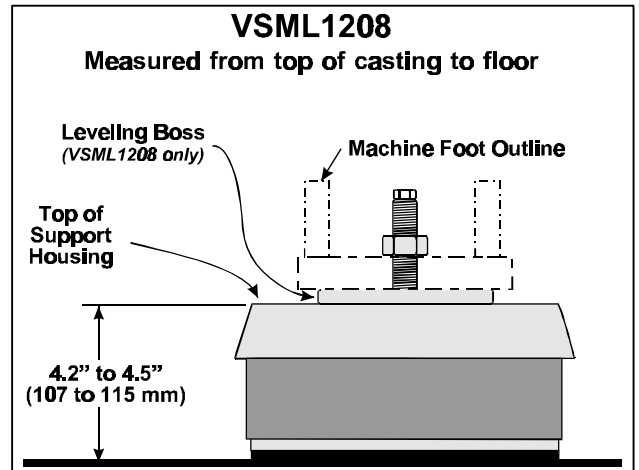

**TIGHTEN LOCKNUTS**

18. Locknuts are provided to fasten the isolators to the machine feet. Use a wrench to hold the leveling screw when tightening the lock nut. A washer may be required, not supplied by Vibro/Dynamics, if the mounting hole is too large.

**ADDITIONAL CONSIDERATIONS**

19. There should not be any solid connections between the machine and the foundation or building structure. Flexible connections are recommended for plumbing and electrical conduit. Floor plates, walkways, railings, etc. should not be attached to both the machine and the floor, foundation or building. Hard connections will “short-circuit” isolation effectiveness.

**Caution:** Vibro/Dynamics Isolators do not bolt to the floor and should not be used to mount machines that depend on anchor bolts to keep them from tipping or collapsing.

<b>Leveling Screw Data</b>		
<b>Leveling Screw Diameter*</b>	<b>Wrench Size (in/mm)</b>	
	<b>Leveling Screw</b>	<b>Lock Nut</b>
1M	.75" (19 mm)	1.5" (38 mm)
1.125M	.75" (19 mm)	1.688" (43 mm)
1.25M	.875" (22 mm)	1.875" (48 mm)
1.5M	1.125" (29 mm)	2.25" (57 mm)
1.75M	1.25" (32 mm)	2.75" (70 mm)
2M	1.5" (38 mm)	3.125" (80 mm)

\* The numbers following the isolator's model number determine the Leveling Screw diameter. For example, use the 1M dimensions if the isolator model is a VSML1208 1M/6.

Call or write for assistance:

Vibro/Dynamics Corporation  
 2443 Braga Drive, Broadview, IL 60155-3941  
 E-Mail: [vibro@vibro-dynamics.com](mailto:vibro@vibro-dynamics.com)

1-800-842-7668 (USA only)  
 1-708-345-2050 Tel.  
 1-708-345-2225 Fax