

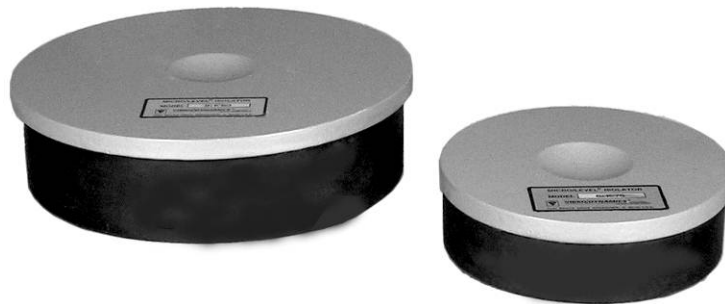

Technical Bulletin M/L – 695

Installation and Leveling Instructions for Vibro/Dynamics “i” Series Micro/Level® Isolators



These Leveling and Installation Instructions are for isolators equipped with “i” style leveling screws. These isolators can be identified by the “i” designation in the isolator’s model number. See examples below:

- 6iK60 IT.7510-5
- 8iL220 I1008-5
- 9iK375 IT1014-5
- 10iM800 IT1014-5

Vibro/Dynamics’ Technologically Advanced Machinery Mounting Systems are an investment in productivity and efficiency. To realize the full potential of your investment, familiarize yourself with these instructions and use them as a reference during the installation.

The way that your machine is installed has a significant effect on its performance. The four conditions required for a good machine installation and best performance are:

- machine bed in one plane (level)
- precise alignment and parallelism of machine structure
- proper support
- effective control of vibration.

Vibro/Dynamics’ Isolators make it possible to accomplish all of these steps to an ultra-high degree of precision and to do so very quickly. When the machine is fine-tuned and leveled, the machine will produce high quality parts with minimum wear and tear on dies and machine components. Downtime, noise, and vibration will be reduced, and productivity and efficiency will be increased.

VIBRO/DYNAMICS

INSTALLATION AND LEVELING INSTRUCTIONS

Micro/Level® “I” Style Isolators are designed to use a machines’ existing leveling screws. The dimple in the top of the isolators will accept most leveling screw designs. As an option, Vibro/Dynamics can supply “i” style leveling screws that match the thread in the machine feet. They come in a few different types as shown in the illustration on the right.

Site Preparation

1. The concrete surface under the isolator must be clean, flat, and trowel finished. There should not be any holes, cracks, or lumps directly under the isolator. Patch all holes and broken concrete.
2. Clean and inspect the machine feet and legs. Repair any cracks or damage. Clean any debris from the threaded mounting holes.

Installation

3. Thread the leveling screws into a suspended machine base.
4. Position each isolator under the machine foot so that it is centered with the leveling screws.
5. Carefully lower the machine onto the isolator, making sure that the leveling screw is centered in the dimple on the top surface of the isolator. See drawing on the right.

Leveling

6. Refer to the machine manual for the machine’s leveling locations and tolerances. Leveling is accomplished by turning the leveling screws into and out of the machine base.
7. Using a precision machinists’ level, electronic level, or laser, determine the machine’s low side in the left-to-right direction. Raise the low side of the machine, by turning all of the leveling screws on the low side an *equal* amount, until the machine is level in that direction. Using a hydraulic jack will make the process easier on heavy machines.
8. Repeat procedure in the front-to-back direction.
9. Repeat Steps 7 and 8 until the machine is level.
10. Do not over adjust the screws. Make sure that leveling screw threads are fully engaged in the machine base.

Caution: Vibro/Dynamics Isolators do not bolt to the floor and should not be used to mount machines that depend on anchor bolts to keep them from tipping or collapsing.

I STYLE LEVELING SCREW TYPES

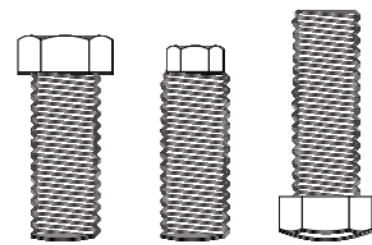

IT * IT * I
ITM * ITM * IM

I = LEVELING SCREW STYLE
T = TOP HEX OPTION
M = METRIC THREAD

* ALL IT AND ITM SCREWS WILL BE CAPPED HEAD UNLESS THREADS ARE A STANDARD I-STYLE SCREW.

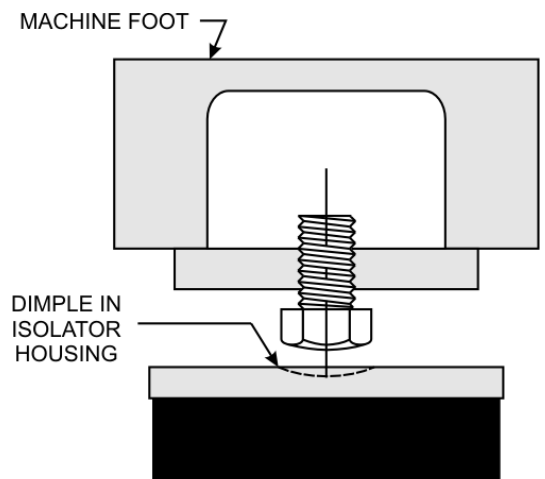

Warranty

Vibro/Dynamics warrants equipment of its own manufacture to be free from defects in materials and workmanship. This warranty extends only to the original buyer, it is for one year only from the date of sale and is limited to repair or replacement, F.O.B. Vibro/Dynamics’ plant, of any original part or component that Vibro/Dynamics finds to have been defective at the time of shipment. Vibro/Dynamics is not liable for consequential damages. This warranty is in lieu of all other warranties, expressed or implied.

Call or write for assistance:

Vibro/Dynamics Corporation
2443 Braga Drive, Broadview, IL 60155-3941
E-Mail: vibro@vibroynamics.com

1-800-842-7668 (USA only)
1-708-345-2050 Tel.
1-708-345-2225 Fax

Vibro/Dynamics®, Micro/Level®, Hydra/Level®, and Hy/Speed® are registered trademarks and Lod/Sen™ is a trademark of the Vibro/Dynamics Corporation. All rights reserved.