



Taming a 2500 Ton Forging Press

Motion Problems Brought Under Control

When Milwaukee Forge Company, in Milwaukee, WI was experiencing difficulty with the installation of their 2500 Ton National Forging press, they decided to contact Vibro/Dynamics Corporation for help.

The press had been installed on a “Type K” Spring Isolation System. The Spring System was causing many headaches for Milwaukee Forge and its Superintendent of Maintenance, Gene Ziarek. The springs were continually breaking, causing unnecessary press downtime and maintenance.

Since the press was mounted in a pit, someone had to go under the press to replace the springs and make repairs. No one wanted this assignment. “People used to call in sick when they knew that this maintenance job was scheduled”, said Gene. Who could blame them! The pit was dark, damp, greasy, and the prospect of laying down to replace springs was very undesirable.

The press also moved excessively on the spring isolation system, due to either misapplication, poor damping or both. The excessive motion caused water lines, electrical conduit, and air lines running to the press to rupture, break and leak. The continual press motion also increased press cycle time, reducing productivity.

After spending quite a bit of valuable time, manpower and money fixing problems caused by the spring isolation system and fixing the spring isolation system itself, a totally new solution was sought. That is when Vibro/Dynamics was called in to analyze the present isolation system and to make recommendations on how to solve Milwaukee Forge’s installation problem.

Spring Isolation Systems do a good job isolating vibration and shock because they are relatively soft when compared to elastomeric isolators. Because Spring Isolators are soft, it is imperative that a thorough analysis of the forces generated by the press be done to determine press motion in advance. Motion can be controlled to some degree by damping systems. But, when it comes to controlling motion, elastomeric isolators work best.

Since excessive motion was the primary problem, Vibro/Dynamics recommended reinstalling the press on four BFM1305/110 Micro/Level® elastomeric isolators. Almost immediately, Milwaukee Forge began to see the benefits.

“We spent \$12,000 to \$13,000 on replacement springs alone”, according to Gene Ziarek. “With the press mounted on Micro/Level Isolators, this cost was eliminated. Not only were savings realized on the replacement springs, but in the manpower required to replace them as well.”

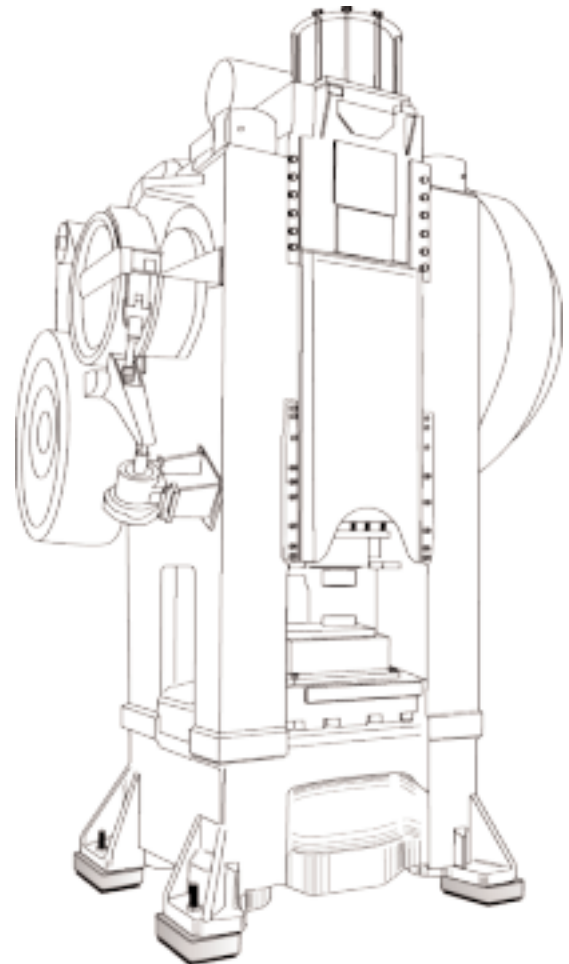

Micro/Level Isolators provide excellent vibration isolation while keeping excessive motion under control.



Taming a 2500 Ton Forging Press

“The press has been installed for seven or eight years and we haven’t had to touch the isolators,” Gene stated. Thanks to Vibro/Dynamics Micro/Level Isolators, the unsavory task of replacing springs has been eliminated.

Press productivity increased after the press was installed on Vibro/Dynamics Isolators. Downtime was significantly reduced since the press no longer had to be shut down to repair broken connections caused by the excessive press motion. Milwaukee Forge was also able to replace the mechanical knockouts on the press with hydraulic ones after the press was reinstalled on Micro/Level Isolators. This meant faster and more consistent production processes and reduced cycle time.

Milwaukee Forge contracted with EWI Engineering Associates to perform vibration tests after the press was reinstalled on the Micro/Level Isolators. In the report, dated October 5, 1990, EWI found that there was no significant increase in the transmission of vibration with the press installed on the Vibro/Dynamics Isolators. With the press mounted on the Micro/Level Isolators, the motion of the press was significantly reduced without sacrificing vibration isolation.

Vibro/Dynamics Isolators are designed to keep a press level and to withstand the harshest plant conditions without fail. They are built to last! Why worry about a press installation if you don’t have to?

In short, Vibro/Dynamics was able to help a customer install a press in a way that would maximize its productivity. Thanks to Vibro/Dynamics’ Micro/Level Isolators, Milwaukee Forge was able to keep its press running, control transmitted vibration, and reduce downtime.

If you ask Gene how he feels about Vibro/Dynamics Isolators, “So far, they have done an excellent job!”

**For more information or a free quotation, call toll-free
1-800-842-7668 or visit us on the web at
www.vibrodynamics.com**

Vibro/Dynamics makes a full range of machinery mounting systems for hundreds of industrial applications. Our products are designed to make machine installation faster and easier, and to increase uptime and profitability by maintaining proper machine alignment, extending die and mold life, and keeping machines level.

VIBRO/DYNAMICS Corporation

2443 Braga Drive
Broadview, IL 60155-3941
E-Mail: vibro@vibrodynamics.com
Web site: www.vibrodynamics.com

Telephone 708-345-2050
Toll-Free in USA 1-800-842-7668
Fax 708-345-2225

Vibro/Dynamics and Micro/Level are registered trademarks of Vibro/Dynamics Corporation.
©2000 Vibro/Dynamics Corp. Printed in USA.
Vibro/Dynamics Products are protected by one or more of the following U.S. Patents:
3,332,647; 4,047,427; 4,135,392; 4,846,436; 4,930,741; 5,360,195; 5,577,703; 5,690,304;
5,738,330 and Foreign Patents.

