



VIBRO/DYNAMICS®
vibration and shock isolation systems

Vibration and Shock Isolation Systems for the Forging Industry



MICRO/LEVEL® Isolators

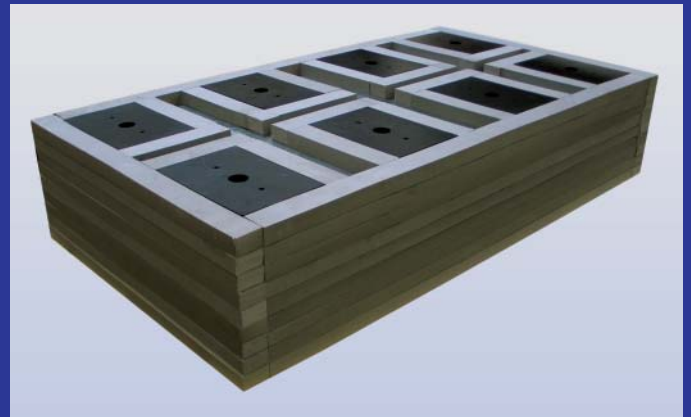

MRM™ & VPS™ Isolation Elements



FSV™ and FSX™ Spring Mounts



*Your best way to install forging machinery
for effective control of vibration and shock*

MRM™ & VPS™ Systems

MRM™ and VPS™ Systems are specially designed for die forgers and drop hammers. These revolutionary new products have the simplicity of a layered elastomer system, with shock isolation effectiveness similar to viscous spring isolators.

MRM Systems feature thicker, softer, elastomer modules for greater vibration and shock control. Vertical dynamic natural frequencies as low as 8 Hz are achievable. Typical isolation efficiency is 60-80% reduction compared to traditional oak-timber systems. VPS Systems use stiffer, higher load capacity, elastomer modules for very effective vibration control in a more economical package.

MRM and VPS Systems feature unitized construction. Each Element is constructed using alternating layers of custom elastomer modules and galvanized steel sheets that are securely fastened together. The elastomer modules are molded from proprietary compounds for superior shock isolation, durability, and creep resistance. Each Element is encased in a protective foam barrier for further protection against pit debris.

All MRM and VPS Elements are designed to be simply lowered into the foundation as complete units. No difficult and time-consuming layout and “in the pit” stacking of pads and plates is required!

The unique design features of the MRM and VPS Isolation Systems result in superior shock isolation, trouble-free installations and long lasting performance.

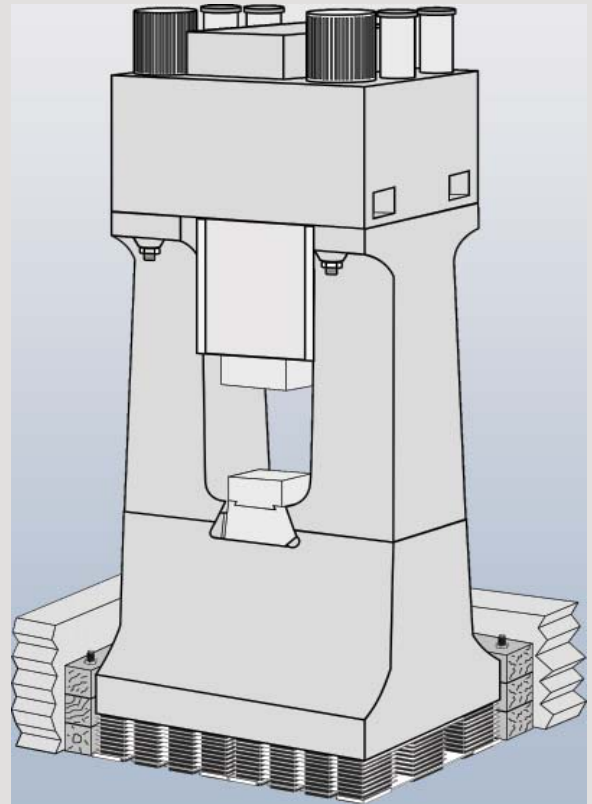

The MRM Isolation Element Concept.

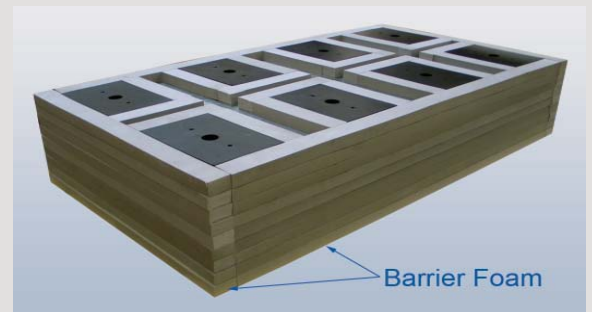

MRM Element Model MRM8x9-0-G



MRM Isolation Elements being lowered into a pit.



Elements quickly installed and arranged in pit.

Viscous Damped Spring Mounts

FSV™ and FSX™ Spring Mounts provide the ultimate in shock isolation effectiveness. Their low stiffness and natural frequency results in shock isolation in the 80-90 percent range. Hammer motion is controlled by a very sophisticated viscous damper design, providing a fast decay of motion between hammer blows.

The heavy-duty, stress relieved fabrication is made to hold-up under the severe operating conditions typical to the forging industry. The FSV coil springs feature protective covers, while the FSX coil springs are totally enclosed within the damper. Both models have rim mounted seals to protect the damper from contamination.

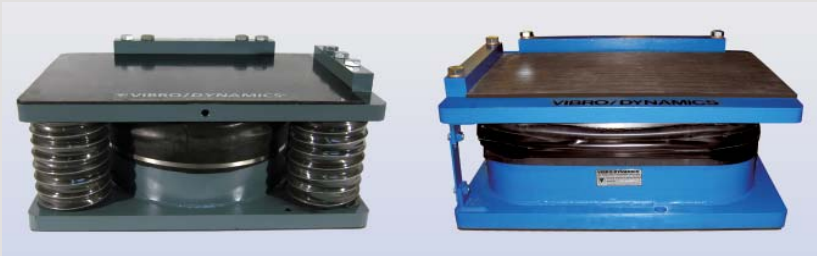

FSV20 and FSX20
Viscous Damped Spring Mounts

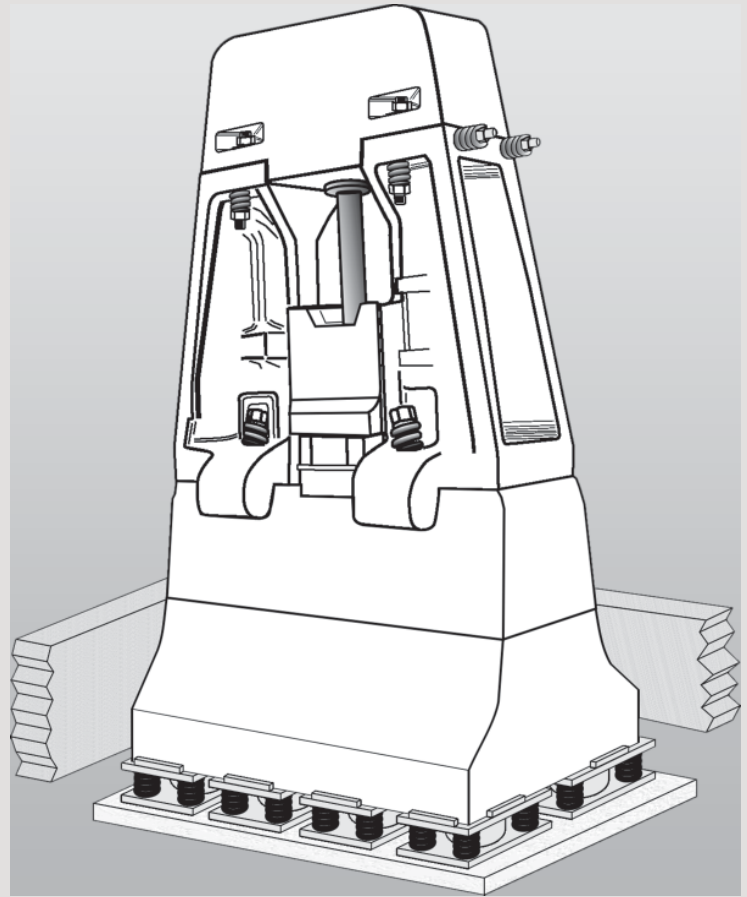

CECO #23 installed on FSV20-164-6S
Viscous Damped Spring Mounts.

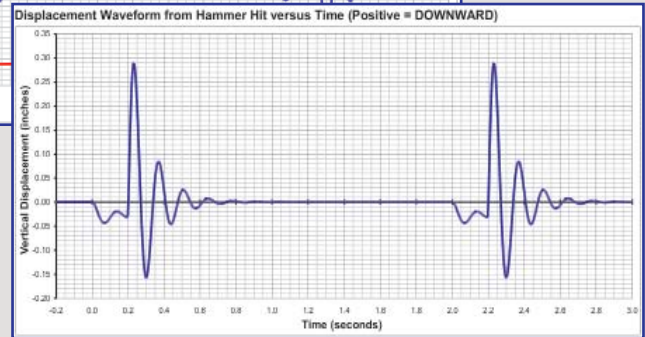
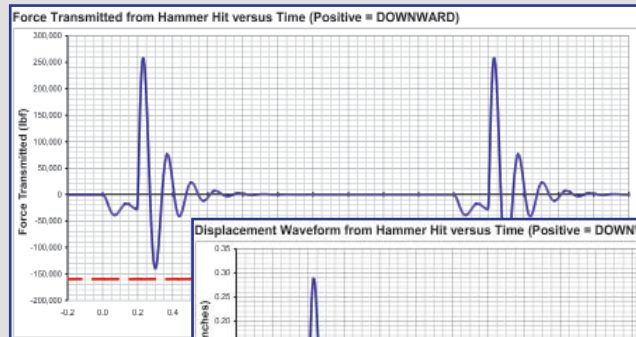

Vibro/Dynamics Engineers carefully analyze every application using proprietary computer modeling software. Motion and force transmission charts can be provided to assist the customer in their hammer installation and foundation design.

Forging Press Installations

Forging presses can be installed using either Vibro/Dynamics® Elastomer Isolators or Viscous Spring Mounts, depending on the installation and isolation requirements.

Micro/Level® Elastomer Isolators offer easier, faster installations, precision leveling and alignment; and excellent vibration and impact force isolation.

FSV™ and FSX™ viscous damped spring isolators are recommended when shock isolation requirements are high. These isolators are relatively soft, so direct mounting of the press on spring isolators may result in greater than desired motion caused by the press rocking forces. Motion can be reduced by using a steel plate or outrigger beams effectively increasing the wheelbase of the machine.

The choice is yours! Vibro/Dynamics Application Engineering Department is available to assist you in the isolator selection process.

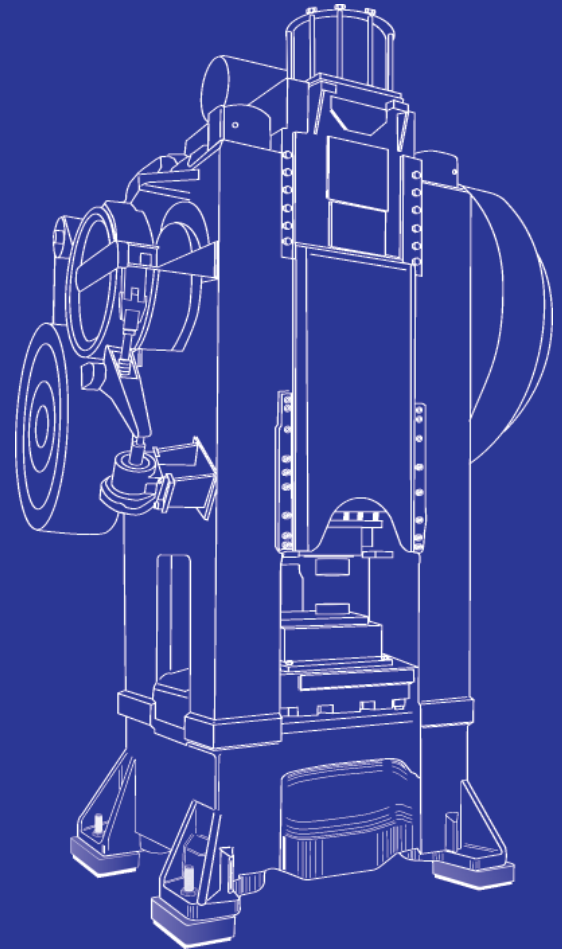

Forging Presses can be installed using Micro/Level® Elastomeric Isolators or FS Type Spring Mounts with outriggers.

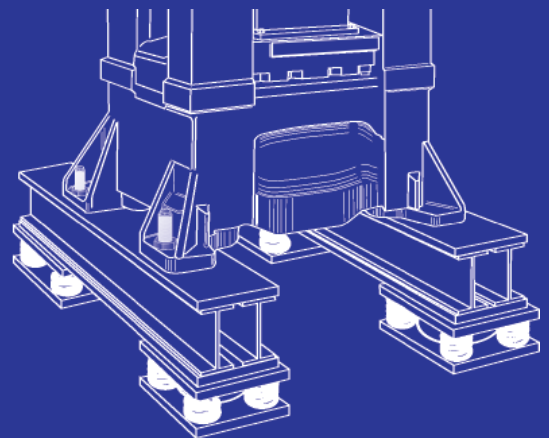

VIBRO/DYNAMICS Corporation

2443 Braga Drive, Broadview, IL 60155-3941

Telephone 708.345.2050 Fax 708.345.2225

Toll-Free 800.842.7668 in the U.S.A.

website - www.vibrodynamics.com

email - vibro@vibrodynamics.com