

HAMMER ISOLATION SYSTEMS

Vibro/Dynamics offers two alternative shock and vibration isolation systems for hammer installations to better fit your needs. The MRM and VPS Elastomeric Isolation Systems are modular systems that use multiple layers of custom-engineered isolation elements. Shock and vibration can be reduced up to 75%, yet the costs are comparable to traditional timber installations. These unitized systems are customized for the installation and are pre-assembled, eliminating any “in-the-pit” arrangement and assembly of elastomer layers.

FSV Hy/Damp™ Coil Spring Isolators offer isolation in the 80-90% range. These isolators provide an improved work environment and less stress on the hammer and its components. Viscous Dampers do an excellent job of controlling motion and heavy-duty construction makes them last!

**Elastomer Support with
MRM Isolation Elements**

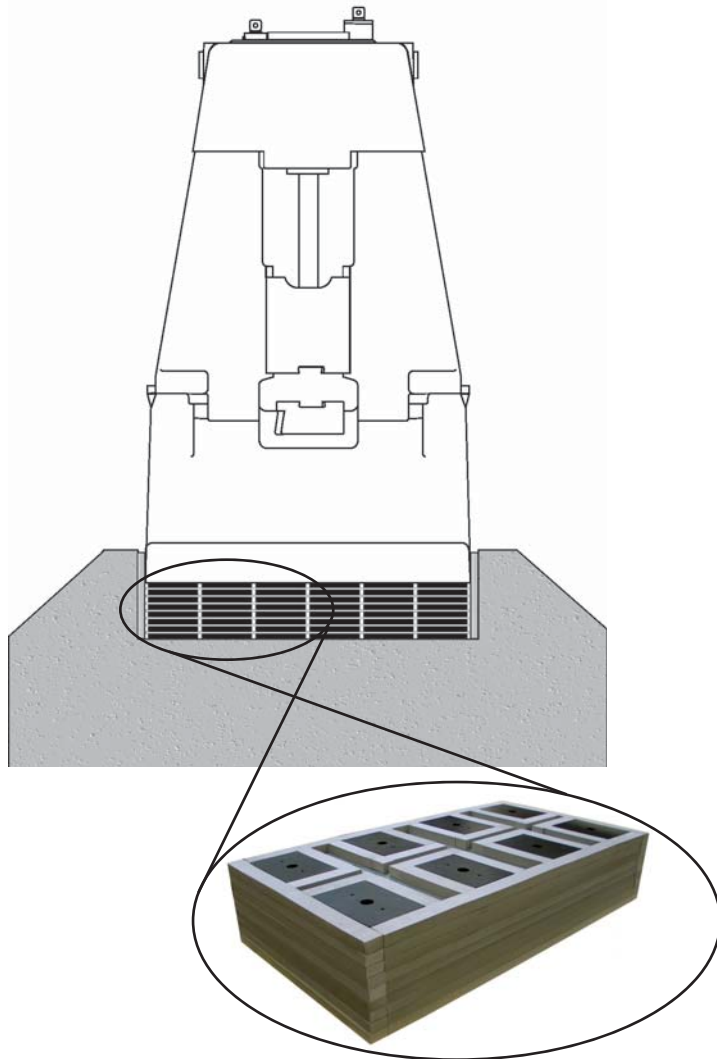

**Direct Spring Support with
FSV Viscous Damped
Coil Spring Isolators**

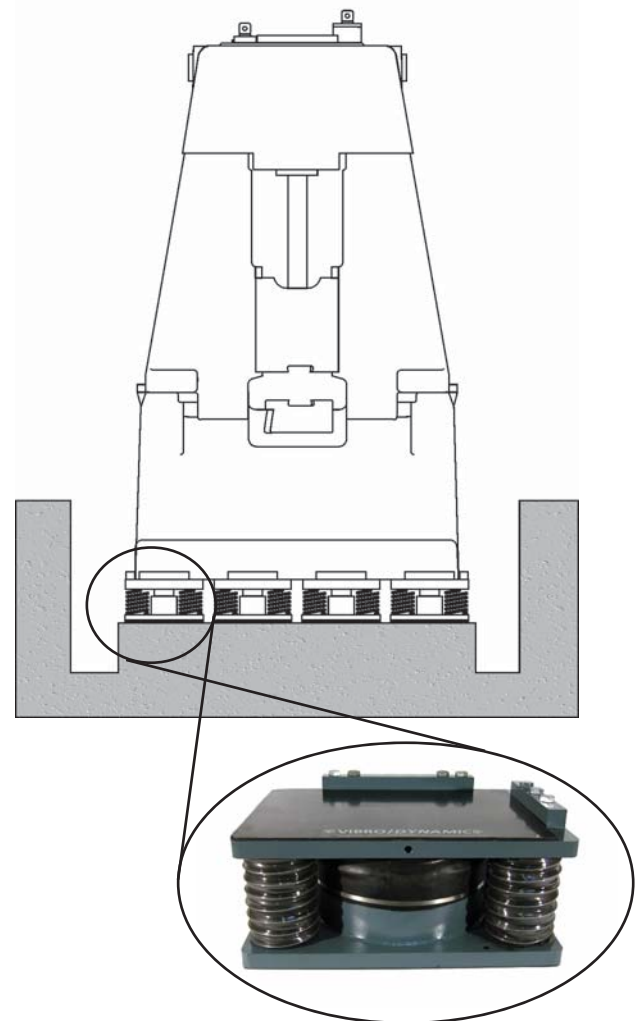

MRM™ & VPS™ Isolation Elements

- 40-75% Shock & Vibration Isolation
- Unitized Construction - Preassembled
- Cost Effective

FSV Hy/Damp™ Spring Isolators

- 80-90% Shock & Vibration Isolation
- Viscous Damping
- Rugged Construction

SERVICES

**Is your present forge isolation system getting hammered?
Time for some preventive maintenance?
If so, Vibro/Dynamics can help!**

We specialize in design and manufacture of vibration and shock isolation systems for forging machinery.

We carry an extensive inventory of replacement parts and viscous damping fluid for Vibro/Dynamics and other spring mount manufacturers.

We can also repair and rebuild your existing spring mounts, whether they are manufactured by Vibro/Dynamics or others.

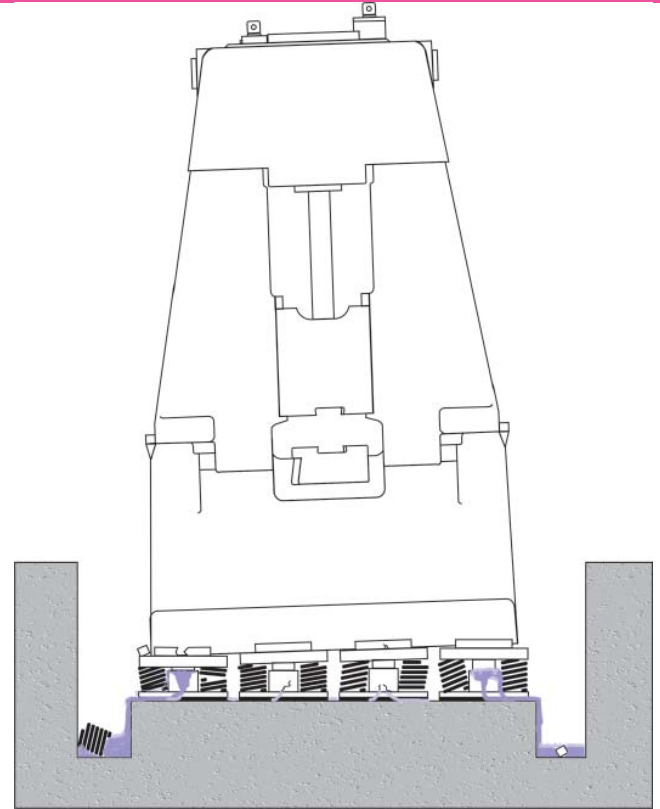

Repair and Rebuild Services are available for most brands of spring mounts.



440 lb. drums of viscous damping fluids are available for various brands and styles of viscous damped steel coil spring mounts.



Springs, isolation pads, straps, keeper bars and other spring mounts components.

Call us to see how we can help!