



# VIBRO/DYNAMICS® RFQ – General Machine Data Sheet

Request for:  Quotation  Budgetary Estimate

## VIBRO/DYNAMICS Corporation

2443 Braga Drive  
Broadview, IL 60155-3941  
Telephone: 1-800-842-7668 or 708-345-2050  
Fax: 708-345-2225  
[www.vibrodynamics.com](http://www.vibrodynamics.com) Email: [Vibro@vibrodynamics.com](mailto:Vibro@vibrodynamics.com)

New Customer Quote No. \_\_\_\_\_

Customer Number: \_\_\_\_\_ Date: \_\_\_\_\_

(For Office Use Only)

Salesman: \_\_\_\_\_

Territory: \_\_\_\_\_

Name: \_\_\_\_\_ Phone: \_\_\_\_\_

Title: \_\_\_\_\_ Fax: \_\_\_\_\_

Company: \_\_\_\_\_ Email: \_\_\_\_\_

Address: \_\_\_\_\_ City: \_\_\_\_\_

State/Province: \_\_\_\_\_ Postal Code: \_\_\_\_\_ Country: \_\_\_\_\_

Send quote via:

Fax

Email

Mail

I. MACHINE DATA English  Metric

Machine Manufacturer: \_\_\_\_\_

Machine Model Number: \_\_\_\_\_

Type of Machine: \_\_\_\_\_

Maximum Part Weight: \_\_\_\_\_

Weight of Fixtures (if any): \_\_\_\_\_

Serial Number: \_\_\_\_\_

Machine Weight: \_\_\_\_\_

Maximum Additional Weight: \_\_\_\_\_

Number of Mounting Points: \_\_\_\_\_

(See Section VI on the next page for more on mounting points.)

## II. OPERATING SPEED RANGES

Main Tool Spindle or Chuck: \_\_\_\_\_ RPM's  Horizontal  Vertical

Motor Spindle: \_\_\_\_\_ RPM's  Horizontal  Vertical

Other Rotating Member: \_\_\_\_\_ RPM's  Horizontal  Vertical

Describe Other Rotating Member: \_\_\_\_\_

Is There A Balancer?  Yes  No What Type? \_\_\_\_\_

## III. TABLE TRAVERSE (if applicable)

Moving Weight: \_\_\_\_\_

Max. Acceleration: \_\_\_\_\_

Max. Velocity: \_\_\_\_\_

Which Axis? (Check those that apply)

x-axis

y-axis

z-axis

## IV. OTHER TRAVERSE ACTIONS (if applicable)

Describe Action: \_\_\_\_\_

Moving Weight: \_\_\_\_\_

Max. Acceleration: \_\_\_\_\_

Max. Velocity: \_\_\_\_\_

Which Axis? (Check those that apply)

x-axis

y-axis

z-axis

## V. PLEASE PROVIDE A GENERAL ASSEMBLY DRAWING, IF POSSIBLE

Machine Manufacturer: \_\_\_\_\_ Model Number: \_\_\_\_\_

VI. CHECK TYPE OF MOUNTING POINT AND LIST APPLICABLE DIMENSIONS

For the following data, please indicate units of measure:  English  Metric

If blind tapped hole: Mounting Hole Diameter \_\_\_\_\_ Pitch \_\_\_\_\_ Depth \_\_\_\_\_

**Type A**

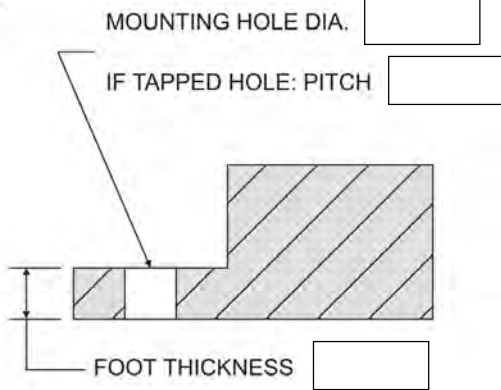

**Type B**

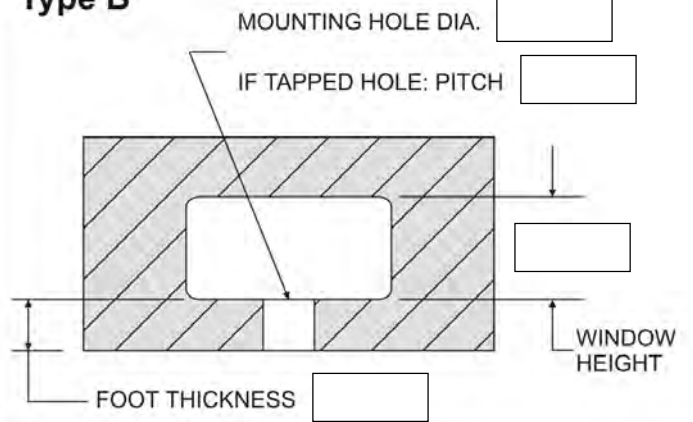

**Type C**

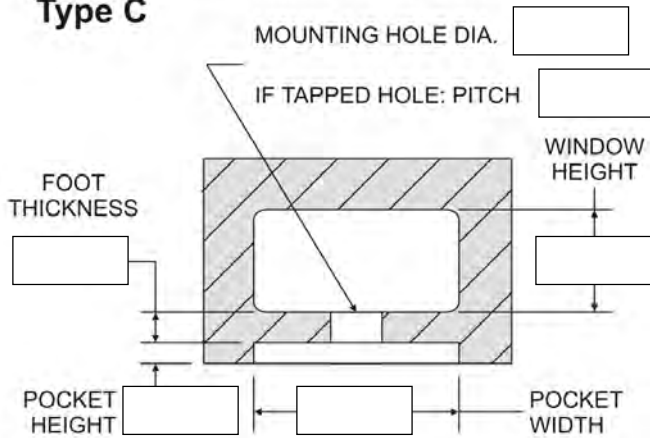

**Type D**

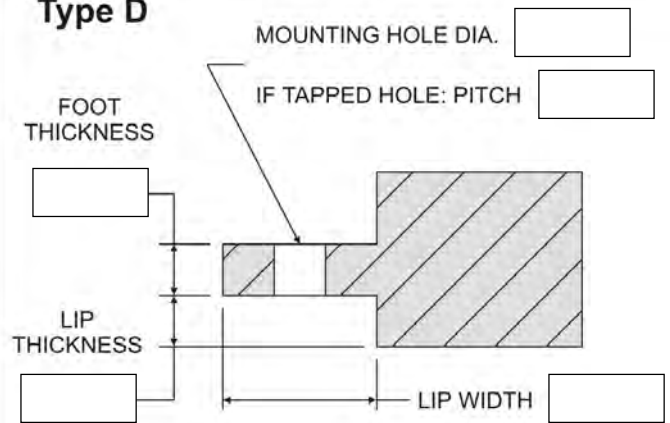

VII. Use the space below for sketches and/or comments on any special considerations.