



VIBRO/DYNAMICS® RFQ – Plastic Injection Molding Machine Data Sheet

Request for: Quotation Budgetary Estimate

VIBRO/DYNAMICS Corporation

2443 Braga Drive
Broadview, IL 60155-3941
Telephone: 1-800-842-7668 or 708-345-2050
Fax: 708-345-2225
www.vibrodynamics.com Email: Vibro@vibrodynamics.com

New Customer Quote No. _____

Customer Number: _____ Date: _____

(For Office Use Only)

Salesman: _____

Territory: _____

Name: _____ Phone: _____
Title: _____ Fax: _____
Company: _____ Email: _____
Address: _____ City: _____
State/Province: _____ Postal Code: _____ Country: _____

Send quote via:

- Fax
- Email
- Mail

Please complete both sides and return to Vibro/Dynamics

I. Machine Data

Machine Manufacturer: _____ Machine Model Number: _____

Machine Type (two-platen, toggle, three-platen): _____ Serial Number: _____

II. Weight Data English Metric

Total Machine Weight (Dry): _____ Moving Weight: _____

Maximum Velocity of Moving Platen: _____

If there are robotics, are they attached to the floor or the machine? _____

If possible, indicate machine weight by section:	
Clamp End: _____	Injection End: _____
Maximum Die Weight: _____	Hydraulic Fluid: _____ <small>(7.5 lbs : 3.4 Kg / Gallon)</small>
Total Weight: _____	Total Weight: _____
Please indicate number of mounting points by section:	
Clamp End: _____	Injection End: _____

Some machine builders have calculated minimum and maximum weights expected at each mounting support point as the moving platen and mold move from one end of the stroke to the other end. If you have a drawing that shows this information, please include a copy or provide us with the project engineer's name and phone number: _____

<i>For office use only</i>	Clamp End Only:
Heaviest Point: _____	Lightest Point _____

III. Expected Installation Date: _____

IV. Please Provide A General Assembly Drawing, If Possible.

Machine Manufacturer: _____ Model Number: _____

V. CHECK TYPE OF MOUNTING POINT AND LIST APPLICABLE DIMENSIONS

For the following data, please indicate units of measure: English Metric

If blind tapped hole: Mounting Hole Diameter _____ Pitch _____ Depth _____

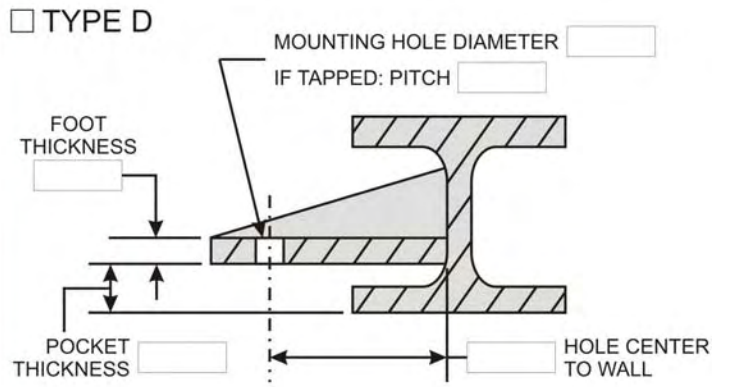
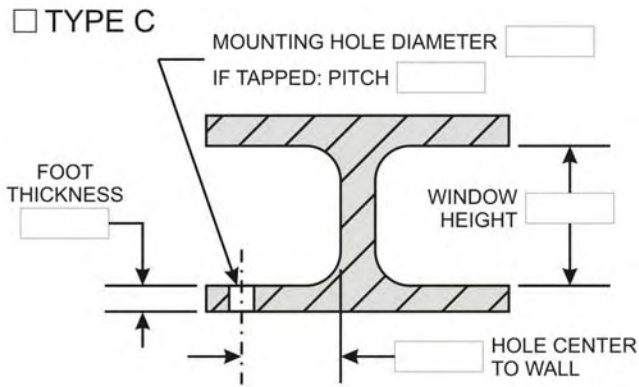
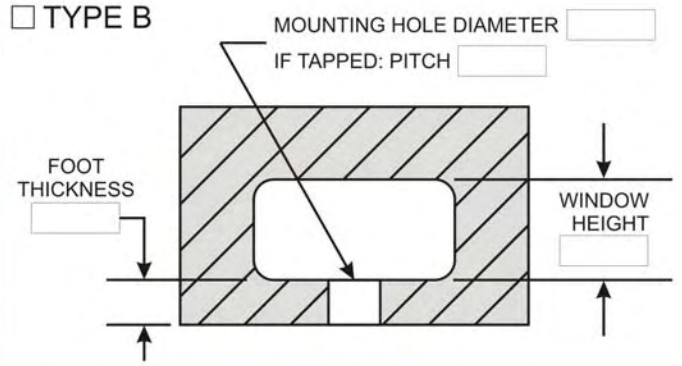
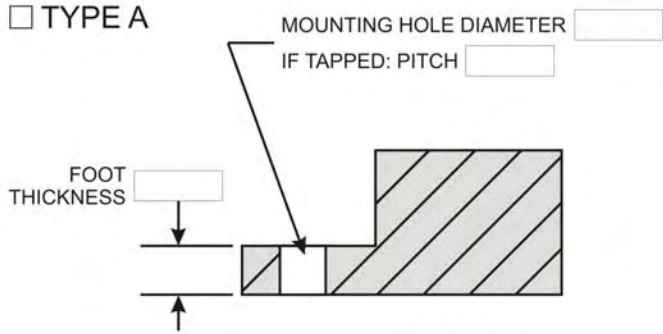

VI. Use the space below for sketches and/or comments on any special considerations.

Blank space for sketches and/or comments on any special considerations.