

7AL MICRO/LEVEL® ISOLATOR SPECIFICATION SHEET

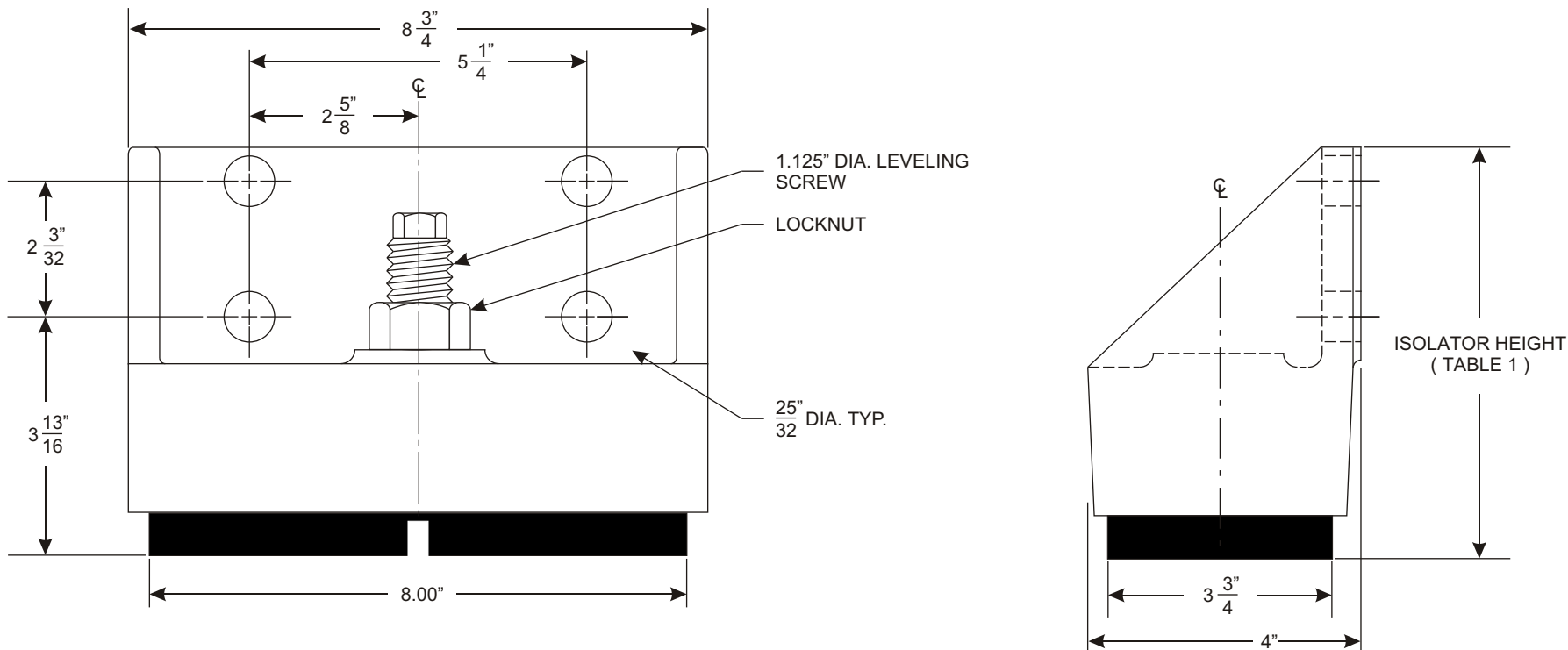

TABLE 1 - Isolator Data

Model Number	Loaded Height ± 0.125		Targeted Installed Height ± 0.125
	Minimum	Adjustable To	
7AL26	6.50"	7.25"	6.875"
7AL50	6.50"	7.25"	6.875"
7AL64	6.50"	7.25"	6.875"
7AL96	6.50"	7.25"	6.875"
7AL120	6.50"	7.25"	6.875"

SS-7AL 05/2001