

7ME MICRO/LEVEL® ISOLATOR SPECIFICATION SHEET

TABLE 1 - Isolator Data Average Ship Wgt. 20 lbs. (9 Kg.)

Model Number	Loaded Height ± 0.125		Targeted Installed Height ± 0.125
	Minimum	Adjustable To	
7ME16	3.75"	4.50"	4.125"
7ME20	3.75"	4.50"	4.125"
7ME28	3.75"	4.50"	4.125"
7ME34	3.75"	4.50"	4.125"

Note: Isolator data subject to change without notice.

TABLE 2 - Leveling Screw Data

Screw Model	Diameter	Thread Length	Pitch	Good for Foot Thickness up to:
1E	1"		14	
1.125E	1.125"		12	

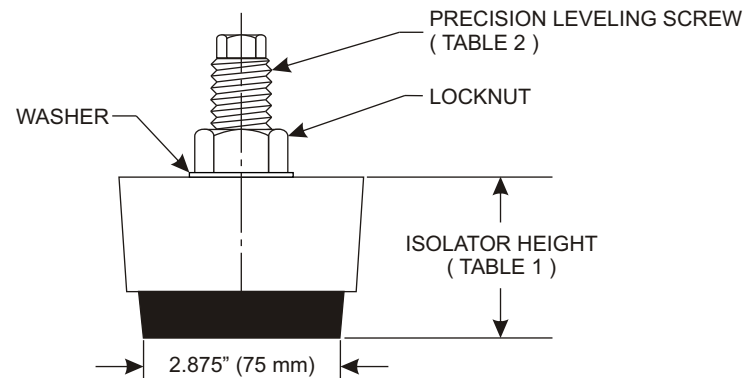
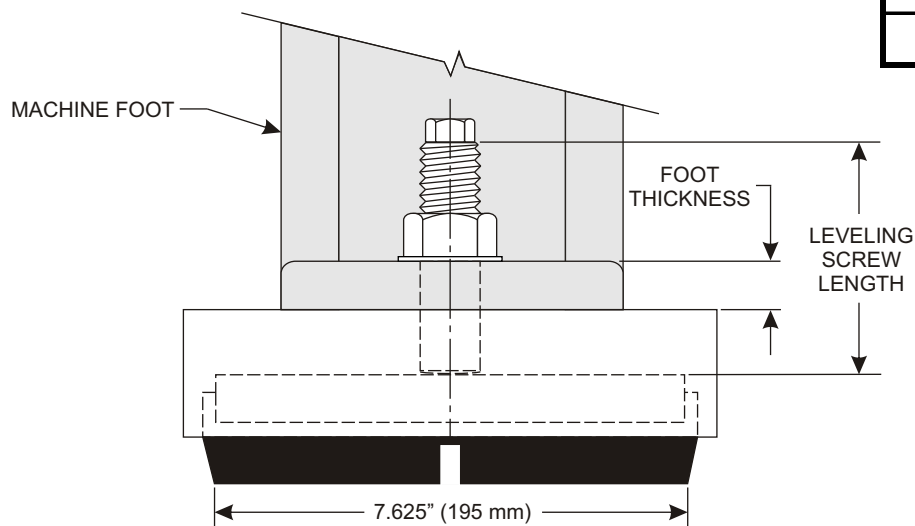
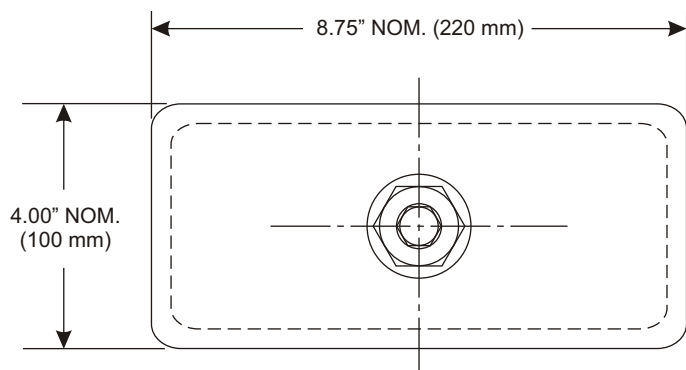

SS-7ME 09/2001