

# D7i MICRO/LEVEL® ISOLATOR SPECIFICATION SHEET

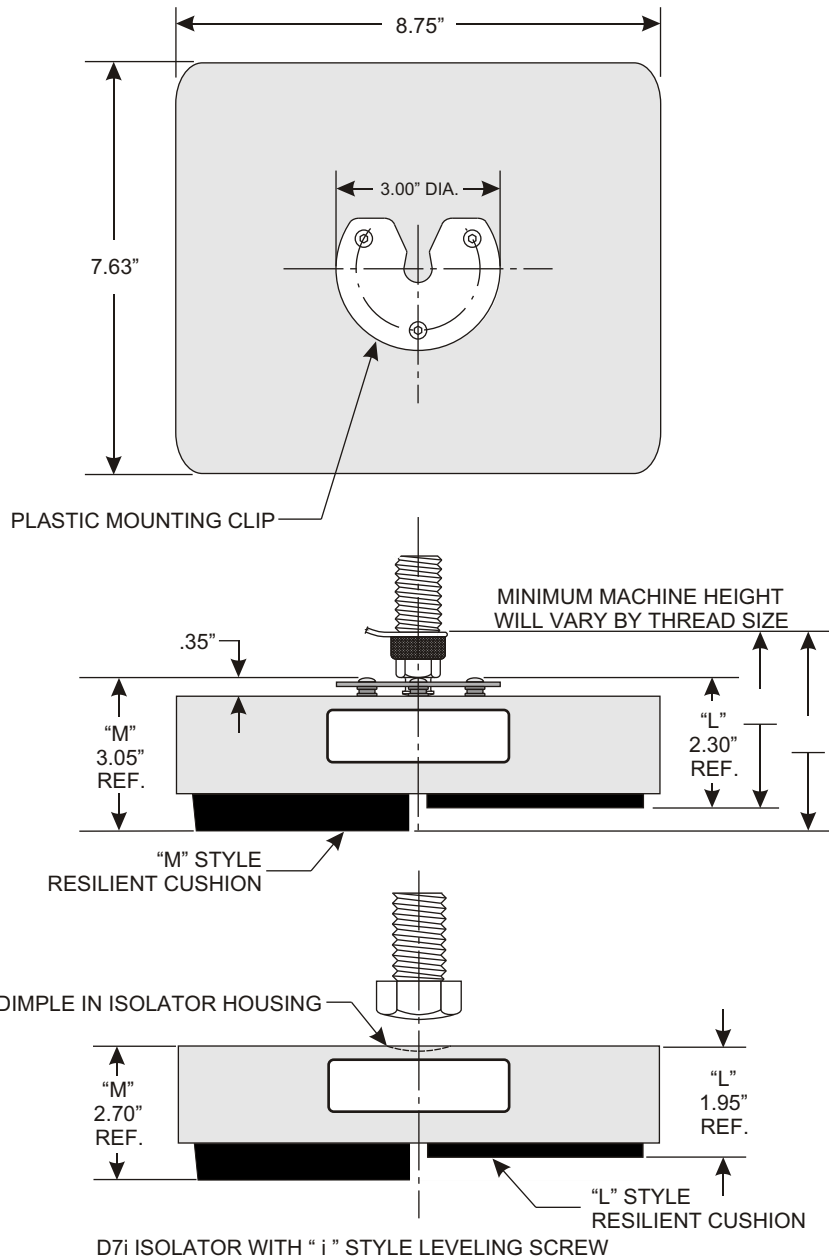

## LEVELING SCREW TYPES

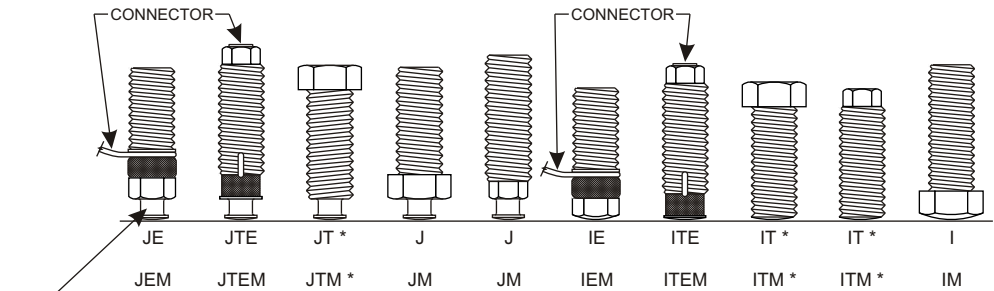

J, I = LEVELING SCREW STYLE    E = LOD/SEN™ OPTION  
 T = TOP HEX OPTION            M = METRIC THREAD

\* ALL JT AND JTM SCREWS WILL BE CAPPED HEAD UNLESS THREADS ARE A STANDARD M-STYLE SCREW SIZE

## Installation Instructions

1. The floor under the isolator should be flat, clean, and dry. With no bumps, holes, or cracks.
2. Thread leveling screws into the suspended machine base.

Leveling screw styles with the letter "T" in the model number thread in from the top. Other styles thread in from the bottom.

LOD/SEN™ screws, with the letter "E" in the model number, must be threaded in until the rubberized area is fully exposed below the bottom of the machine base.

3. For isolators equipped with "J" style leveling screws and plastic clips, attach the isolators to the leveling screws by placing the open end of the plastic clip onto the necked down portion of the leveling screw and then snap into place. The isolator should hang freely.
4. With the isolators hanging from the machine base, carefully lower the machine into place.
5. For isolators equipped with "I" style or customer supplied leveling screws, make sure that the bottom of the leveling screw is centered in the dimple of the isolator housing.
6. Level the machine by turning the leveling screws into and out of the machine base. Do not over adjust and make sure the leveling screw threads are fully engaged in the machine base.

## Model Number:



SS-D7i 04/2002