

9 SERIES LOD/SEN™ MICRO/LEVEL® ISOLATOR SPECIFICATION SHEET

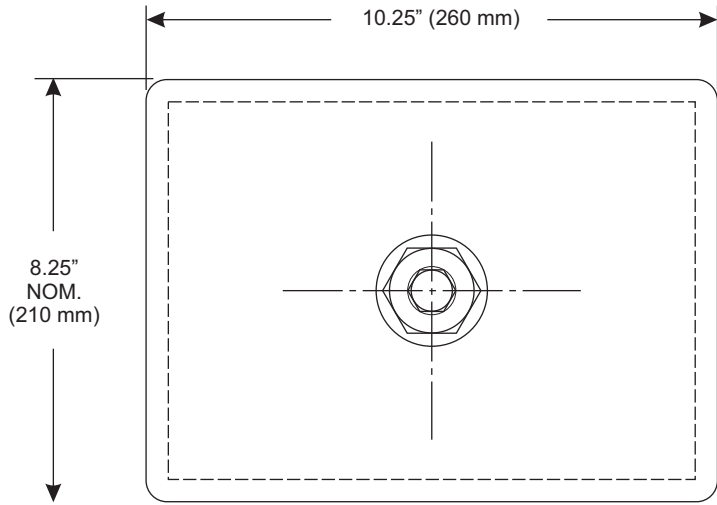
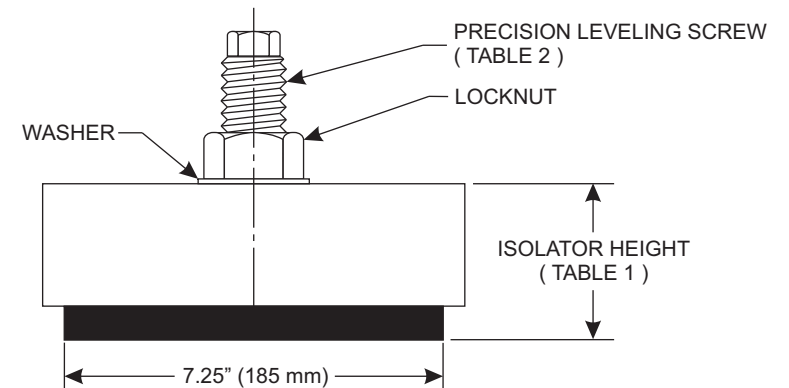
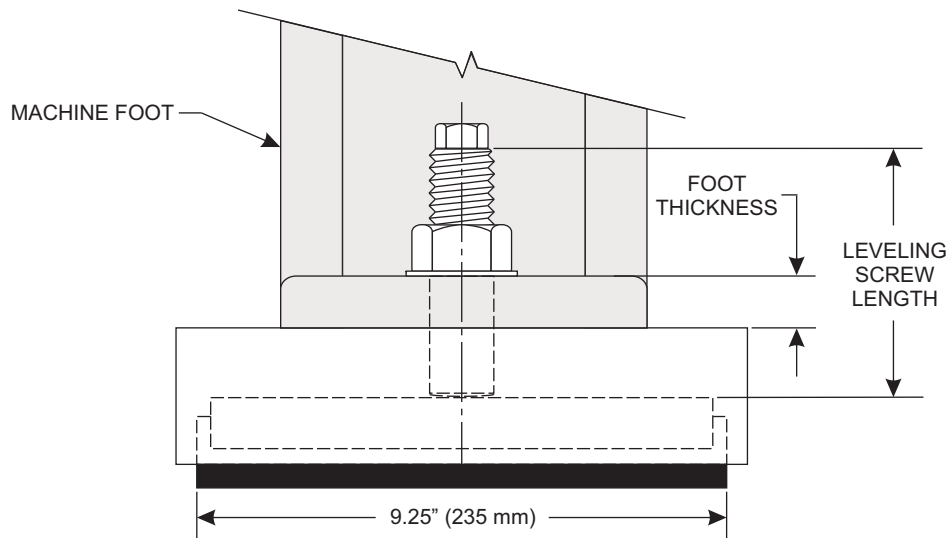

TABLE 1 - Isolator Data (Approx. Shipping Wt. 32 lbs./15 Kg.)

Model Number	Loaded Height $\pm 0.125"$ (3.18 mm)				Targeted Installed Height $\pm 0.125"$ (3.18mm)	
	Minimum		Maximum		inch	mm
	inch	mm	inch	mm		
9ME580	3.75	96	4.50	115	4.13	105
9ME680	3.75	96	4.50	115	4.13	105
9ME780	3.75	96	4.50	115	4.13	105
9ME880	3.75	96	4.50	115	4.13	105
9LE180	3.13	80	3.88	99	3.51	90
9LE250	3.13	80	3.88	99	3.51	90
9LE350	3.13	80	3.88	99	3.51	90
9KE225	2.75	70	3.50	89	3.13	80
9KE275	2.75	70	3.50	89	3.13	80
9KE375	3.13	80	3.88	99	3.51	90
9KE500	2.75	70	3.50	89	3.13	80

TABLE 2 - Leveling Screw Data

Screw Model	Diameter	Thread Length	Pitch	Good for Foot Thickness up to:
1M	1.00"		14	
1.125M	1.125"		12	



SS-9 Lod/Sen 2007.11

9 SERIES MICRO/LEVEL® ISOLATOR

ISOLATOR COMPONENTS

Vibro/Dynamics 9 series isolators have the following components:

○ A neoprene resilient cushion designed to provide the best combination of isolation effectiveness and machine stability. The cushions are designed and compounded to have a long effective life and to be resistant to oils and lubricants.

○ An internal heavy-duty steel bearing plate to evenly distribute the weight and dynamic forces over the entire area of the resilient cushion.

○ A high-strength ductile iron support housing to properly support the machine foot.

○ A high strength leveling screw to precisely adjust the isolator height and to secure the isolator to the

machine foot. The isolator height adjustment provides the means to level the machine, to fine-tune the support of the machine structure, to reduce residual bending and twisting moments in the machine and to compensate for differences in the floor/foundation level.

○ A lock nut to secure the isolator to the machine foot. Two nuts may be used in some applications.

Installation Tools & Equipment

During the installation, you will need the ordinary tools for leveling a machine, (i.e. Open-end or box wrenches to fit the leveling screw and locknut, and a calibrated machinists' level.) A hydraulic jack capable of supporting at least half of the machine weight should be used to support the machine feet while adjusting the leveling screw.

Preparation of Foundation Surface

Ideally, the isolators should be set on a dry, flat and level concrete surface with a smooth trowel or flat finish. The surface does not have to be smooth, ground and polished, but there should not be any holes, joints, cracks or bumps in the floor surface directly under the isolator. Remove all loose concrete, chips, oil, grease and water from the foundation surface that will support the isolator.

Preparation of Machine Feet

Before installing Vibro/Dynamics' isolators, remove all loose concrete, chips, oil, grease and water from the machine feet or base. Clean out the mounting holes in the machine feet. To obtain a uniform bearing surface, the bottom of the machine feet should also be clean and flat where they contact with the top of the isolator. In some cases it may be necessary to scrape, file or grind the bottoms of the machine feet. After cleaning, inspect the machine legs and feet, and repair or replace them if they are broken or cracked. The isolator effectiveness is not

Reduced if the machine foot does not cover the entire area of the isolator support housing. Internally, the heavy-duty steel bearing plate will transfer the load uniformly over the resilient cushion.

Screw & Nut Dimensional Data

Leveling Screw Diameter	Screw Head	Nut	
	Distance Across Flats	Distance Across Flats	Distance Across Corners
.625" (M)	.438"	.938"	1.083"
.625" (C)	1.06"	.938"	1.083"
.750" (M)	.375"	1.125"	1.299"
.750" (C)	1.25"	1.125"	1.299"
1.00"	.750"	1.50"	1.732"
1.125"	.750"	1.688"	1.949"

Additional Considerations

There should not be any solid connections between the isolators or machine and the building structure. Flexible connections are recommended for plumbing and electrical conduit. Floor plates, walkways, railings and the like should not be attached to both the machine and the building. You want to eliminate paths that would allow impact forces and vibration to bypass the isolators.

Leveling Screw Length Selection Chart

Leveling Screw Model	Good for foot thickness up to:
.625M4	1.03"
.625C5	1.78"
.625M5	2.03"
.625M6	3.03"
.625M8	5.03"
.625M10	7.03"
.75M4	1.11"
.75C5	1.86"
.75M5	2.11"
.75M6	3.11"
.75M8	5.11"
.75M10	7.11"
1M4	.98"
1M5	1.98"
1M6	2.98"
1M8	4.98"
1M10	6.98"
1M12	8.98"
1M14	10.98"
1.125M6	2.92'
1.125M8	4.92"
1.125M10	6.92"
1.125M12	8.92"

SS-9 Series Page2 06/2001