

9 SERIES MICRO/LEVEL® ISOLATOR SPECIFICATION SHEET

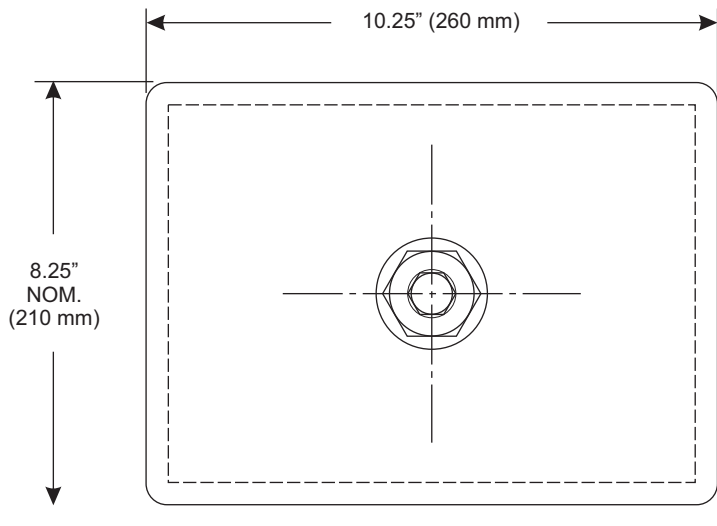
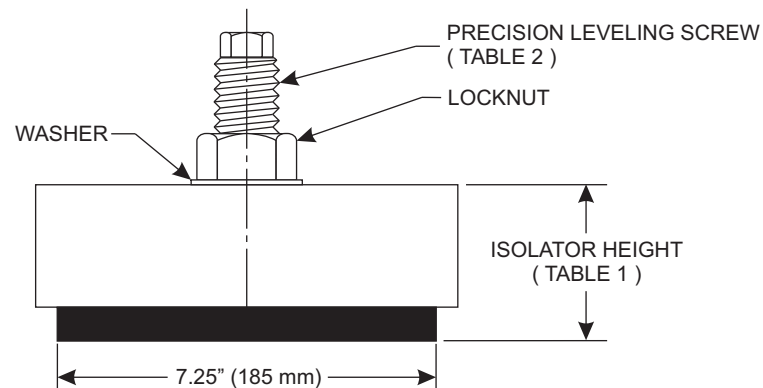
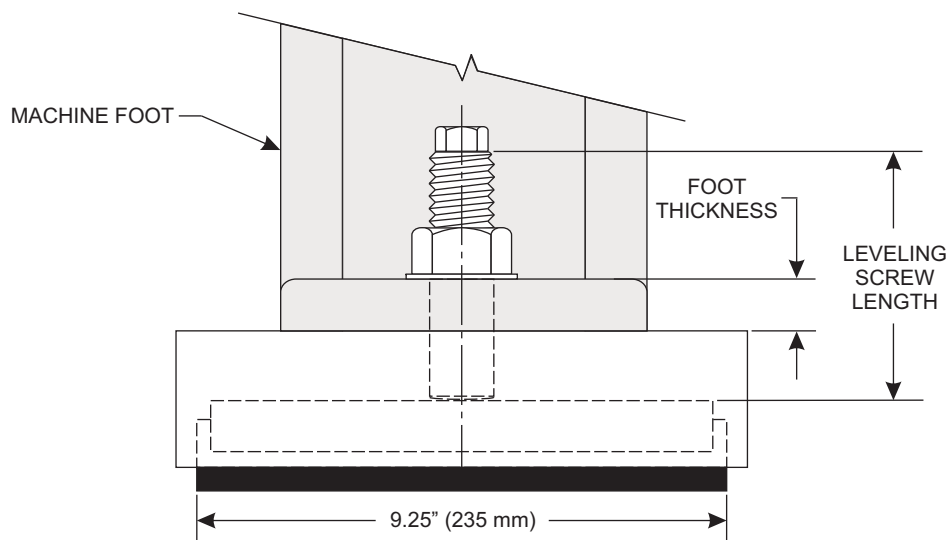

TABLE 1 - Isolator Data (Approx. Shipping Wt. 32 lbs./15 Kg.)

Model Number	Loaded Height $\pm 0.125"$ (3.18 mm)				Targeted Installed Height $\pm 0.125"$ (3.18mm)	
	Minimum		Maximum		inch	mm
	inch	mm	inch	mm		
9M580	3.75	96	4.50	115	4.13	105
9M680	3.75	96	4.50	115	4.13	105
9M780	3.75	96	4.50	115	4.13	105
9M880	3.75	96	4.50	115	4.13	105
9L180	3.13	80	3.88	99	3.51	90
9L250	3.13	80	3.88	99	3.51	90
9L350	3.13	80	3.88	99	3.51	90
9K225	2.75	70	3.50	89	3.13	80
9K275	2.75	70	3.50	89	3.13	80
9K375	2.75	70	3.50	89	3.13	80
9K500	2.75	70	3.50	89	3.13	80

TABLE 2 - Leveling Screw Data

Screw Model	Diameter	Thread Length	Pitch	Good for Foot Thickness up to:
.625M	0.625		11	
.75M	.75"		10	
1M	1.00"		14	
1.125M	1.125"		12	



SS-9 Series 2007.11