

# 10 SERIES LOD/SEN™ MICRO/LEVEL® ISOLATOR SPECIFICATION SHEET

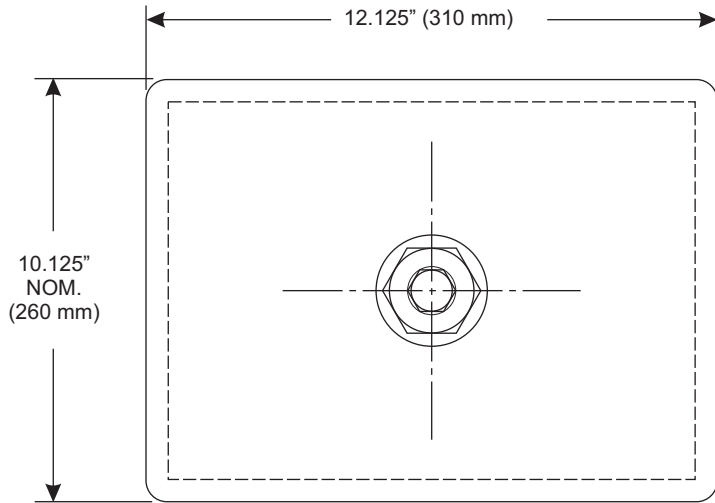
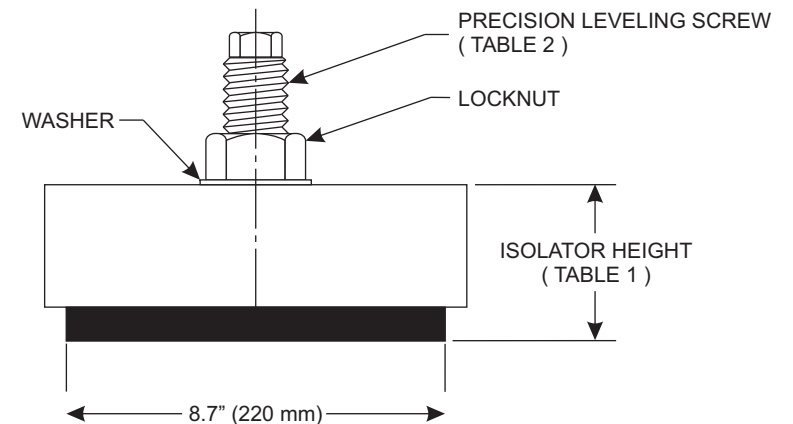
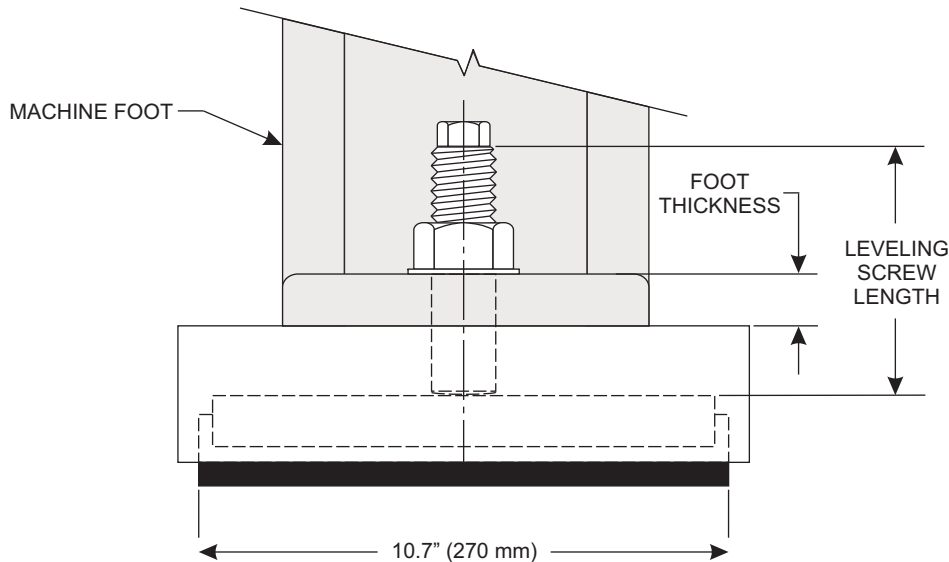

**TABLE 1 - Isolator Data (Approx. Shipping Wt. 56 lbs./26 Kg.)**

Model Number	Loaded Height $\pm 0.125"$ ( 3.18 mm )				Targeted Installed Height $\pm 0.125"$ ( 3.18mm )	
	Minimum		Maximum		inch	mm
	inch	mm	inch	mm		
10ME550	4.0	102	4.75	121	4.38	112
10ME880	4.0	102	4.75	121	4.38	112
10ME1200	4.0	102	4.75	121	4.38	112
10LE200	3.38	86	4.13	105	3.75	96
10LE300	3.38	86	4.13	105	3.75	96
10LE450	3.38	86	4.13	105	3.75	96
10LE600	3.38	86	4.13	105	3.75	96
10LE900	3.38	86	4.13	105	3.75	96
10KE650	3.25	83	4.00	102	3.63	93
10KE950	3.25	83	4.00	102	3.63	93

**TABLE 2 - Leveling Screw Data**

Screw Model	Diameter	Thread Length	Pitch	Good for Foot Thickness up to:
1E	1.00"		14	
1.125E	1.125"		12	
1.25E	1.25"		12	



SS-10LS 2007.11