

# 12W-2 MICRO/LEVEL® WEDGE ISOLATOR SPECIFICATION SHEET

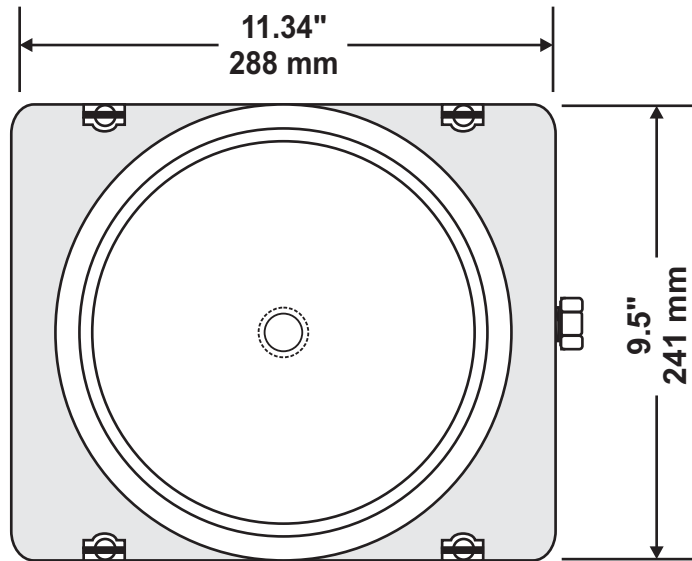

DIMENSIONAL DATA						
Model Number	Loaded Height $\pm 0.125"$ ( 3.18 mm )				Targeted Installed Height $\pm 0.125"$ ( 3.18mm )	
	Minimum		Maximum			
	inch	mm	inch	mm	inch	mm
<b>With Hold-Down Plate</b>						
12WM_2	6.9	176	7.8	199	7.35	187
12WL_2	5.7	145	6.6	168	6.15	157
12WK_2	4.9	125	5.8	148	5.35	136
<b>With Friction Pad</b>						
12WM_2	6.4	163	7.3	186	6.85	174
12WL_2	5.2	133	6.1	155	5.65	144
12WK_2	4.4	112	5.3	135	4.85	124

Note: Isolator data subject to change without notice.

Elevation Adjustment per turn of Adjustment Screw - 0.022" (0.56 mm)  
 (Adjustment does not include any changes in elastomer deflection due to changing load)

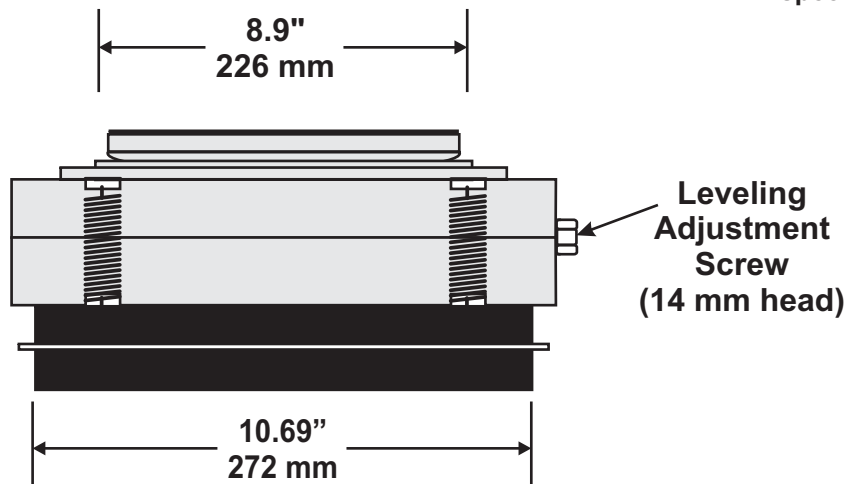

Isolator is furnished with either a friction top pad or an on-center 3/4" or 1" hold-down bolt. Off-center hold-down bolt configurations available as specials.

