

Nivell® DK Double-Wedge Anchoring Systems

The Nivell® DK Anchoring System has a unique double wedge design that makes leveling and aligning machines much easier than with mounts having a single wedge design. Double lifting wedges move together, distributing the vertical and horizontal forces equally about the center load area. Equalizing these forces around the center results in an absolutely rigid and stable anchoring system.

As load is distributed through two lifting wedges, the force required to raise or lower a machine is halved, resulting in effortless and precision leveling of very heavy machines.

Description	Unit of Measure	Nivell Model Number and Product Code		
		DK-2 3500	DKS-2	DK-4 3700
Load Data				
Max. allowable load per mount	lbs.	33,700	33,700	89,900
Spring constant	lb./inch	28,600,000		42,800,000
Torque Data				
Approximate torque required to turn adjustment screw	ft. lb./1000 lbs.	1.3	1.3	1.6
Torque required to turn adjustment screw at max. load	ft. lb.	59	59	148
Dimensional Data				
Height - unadjusted	inch	2.8	3.03	4.02
Length x width	inch	7.32 x 4.72	7.32 x 4.72	10.75 x 9.45
Adjustment screw hex head	mm	17	17	24
Vertical Adjustment Data				
Per revolution of height adjusting screw	in.	0.015	0.015	0.015
Maximum vertical adjustment	in.	0.28	0.28	0.39
Spacer vertical adjustment	in.	0.16	0.16	0.2

The Double Wedge System

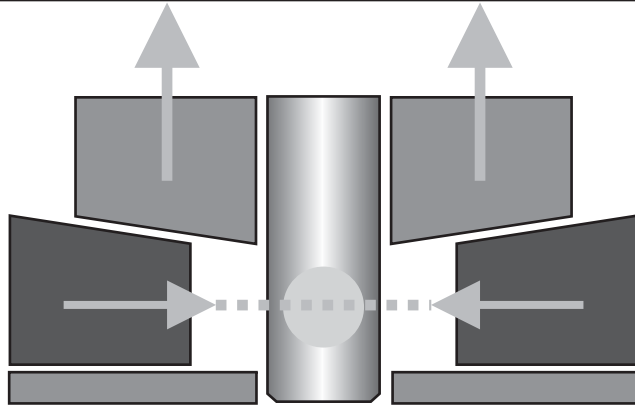

The mechanics of the design:

- All forces are directed toward the center, resulting in an absolutely stable machine.
- Mount stiffness is consistent throughout its leveling range.

The double wedge construction has several advantages over the single wedge designs.

Since there are two wedges, only half the effort is required to make leveling adjustments. Precision leveling and alignment adjustments are faster and easier. The adjustment screw always maintains a positive

engagement with the wedges, eliminating any “slop” or play in the mechanism. Downward adjustments are no problem!

The double wedge design symmetrically distributes loads about the center bolt area. The mount raises and lowers the machine with no horizontal shifting.

The high rigidity of the mounts and the spherical bearing plate ensures that all vertical and horizontal forces generated by the machine are evenly distributed through the mount and into the floor, resulting in an absolutely rigid mounting system.

LIT-Nivell 2009.05

VIBRO/DYNAMICS Corporation · 2443 Braga Drive · Broadview, IL 60155-3941 USA

email: vibro@vibrodynamics.com · Telephone: 708-345-2050 · Fax: 708-345-2225

Nivell® DK-2 D21 Series Adjustable Anchoring Wedges

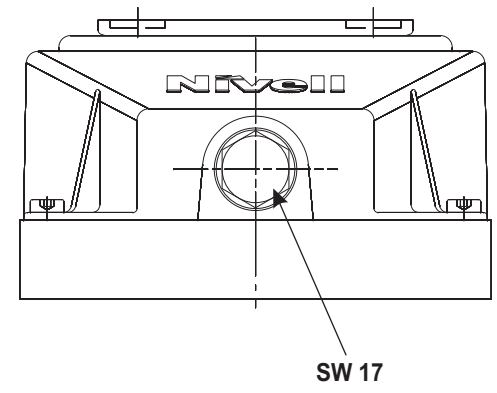
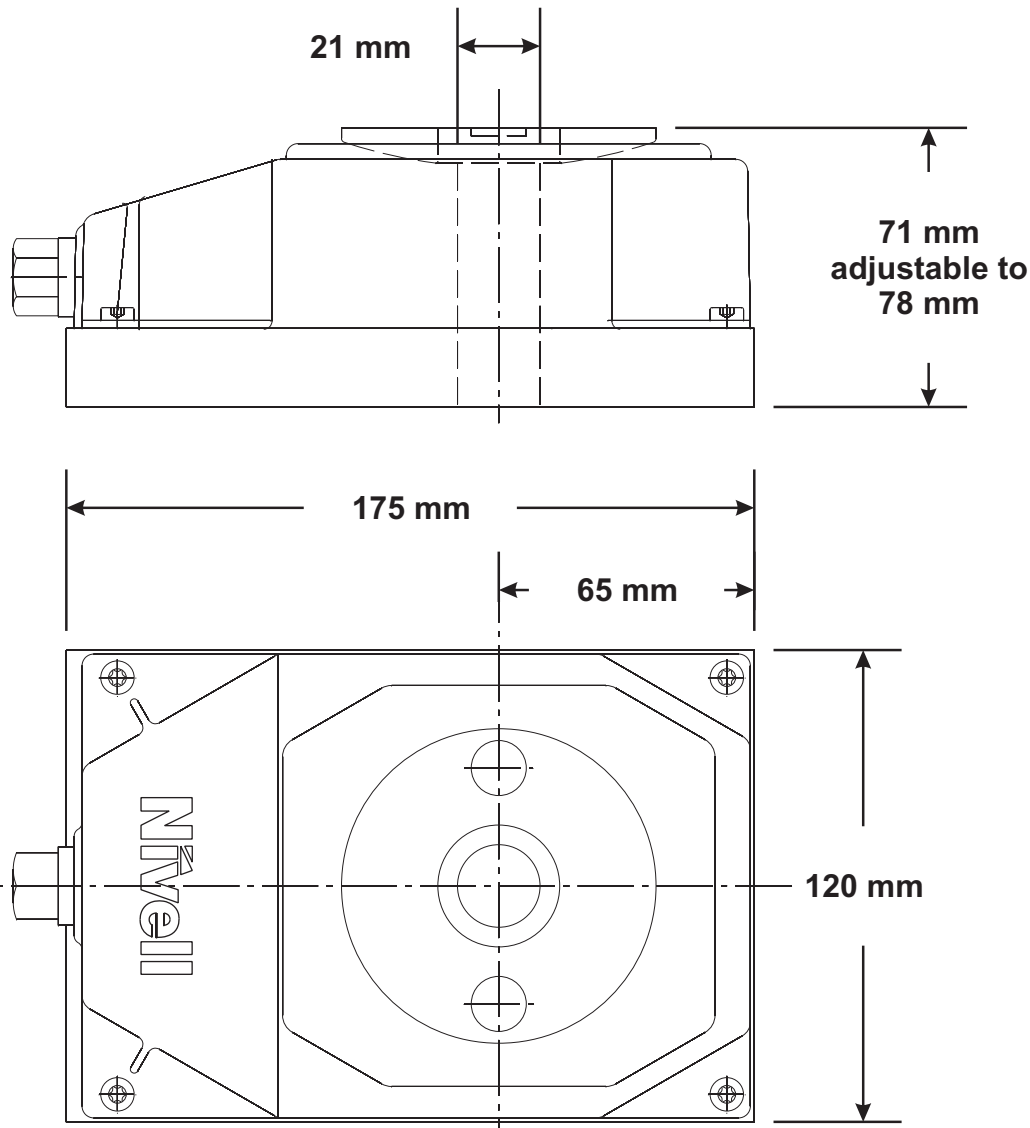

Nivell® DKS-2 M20 Series Adjustable Anchoring Wedges

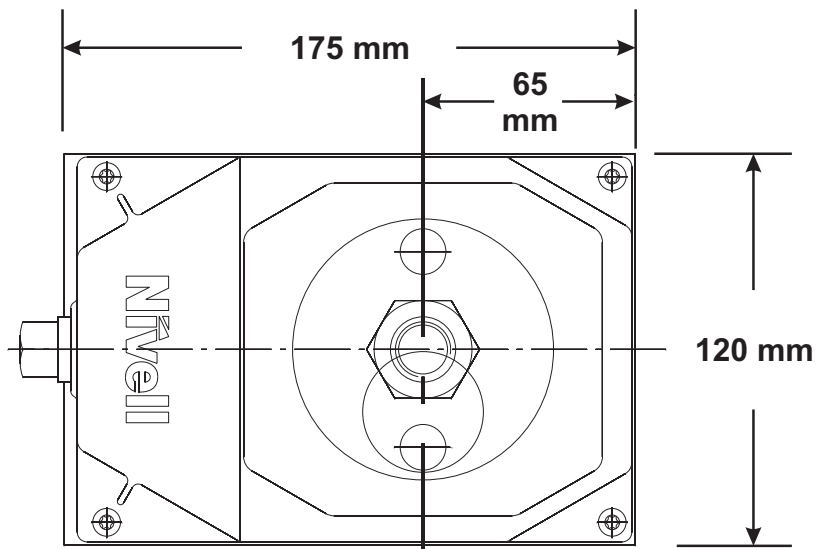
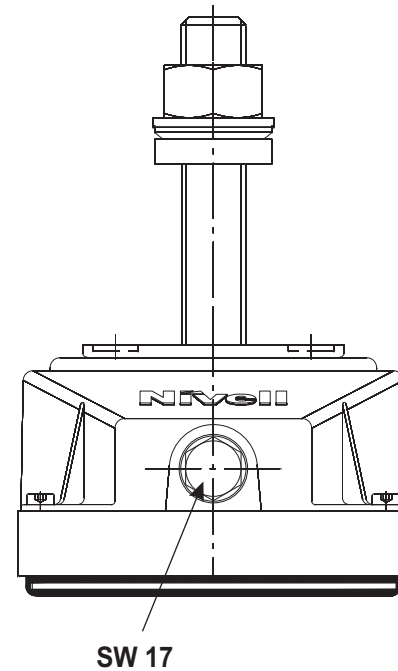
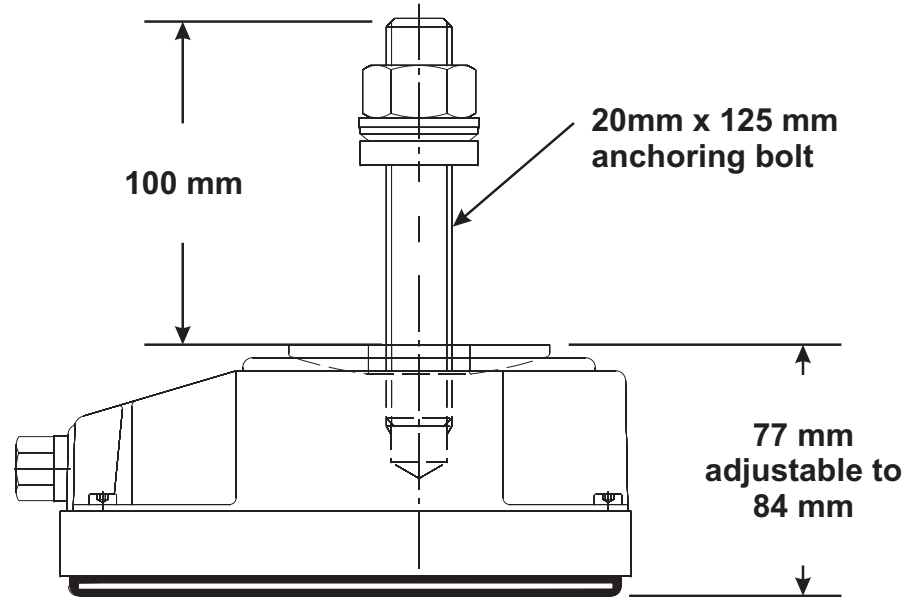

Nivell® DK-4 Series Adjustable Anchoring Wedges

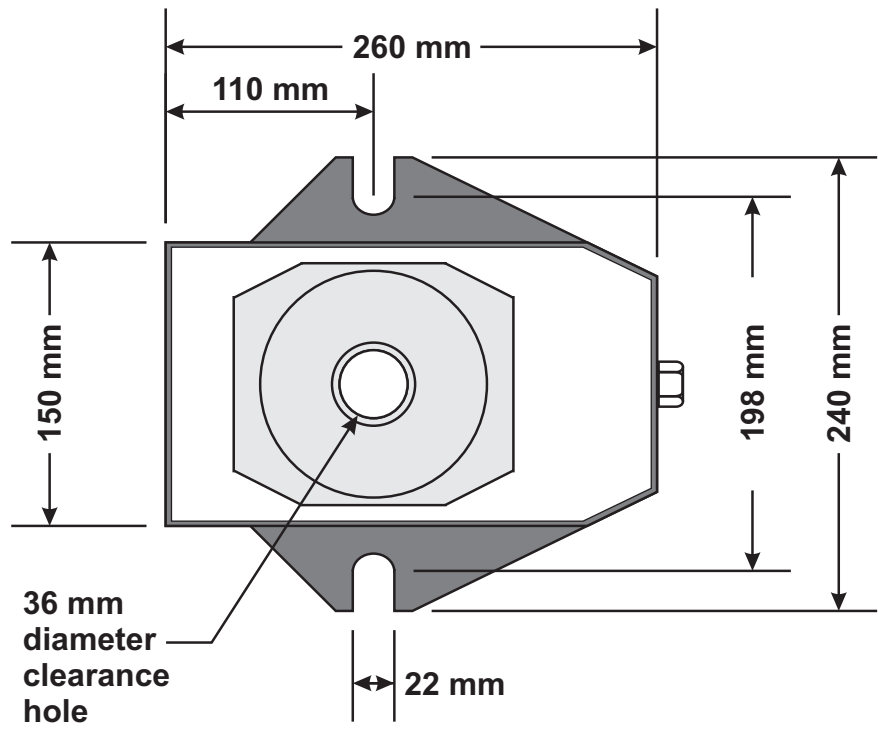

Description	Unit of Measure	Nivell Model Number
		DK-4
Load Data		
Max. allowable load per mount	lbs.	89,900
Spring constant	lb./inch	42,800,000
Torque Data		
Approximate torque required to turn adjustment screw	ft. lb./1000 lbs.	1.6
Torque required to turn adjustment screw at max. load	ft. lb.	148
Dimensional Data		
Height - unadjusted	inch	4.02
Length x width	inch	10.75 x 9.45
Adjustment screw hex head	mm	24
Vertical Adjustment Data		
Per revolution of height adjusting screw	in.	0.015
Maximum vertical adjustment	in.	0.28
Spacer vertical adjustment	in.	0.20

